

Mobile control unit

- Proportional spool function
- Integrated 2-way pressure compensator per section
- Very flexibly combinable
- $Q_{max} = 180 \text{ l/min}$ (without compensator 200 l/min)
- $p_{max} = 420 \text{ bar}$

PMV-16

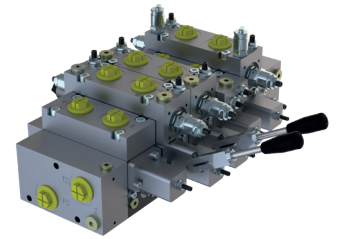

DESCRIPTION

The PMV concept is constructed to offer a high level of modularity. It allows a configuration of individual modules, which are available as pre-assembled units with their own type code. Modifications, to and between them, can also be carried out quickly in the field.

Due to the modular design, special solutions can also be created in a flexible manner. For example, counterbalance valves integrated in the connection plate or operated non-return valves can be integrated. By means of the 2-way pressure compensator, the flow can be controlled independent from the load.

APPLICATION

The areas of application offer great diversity. PMV are used where compact installation dimensions are required and a function requires sensitively controlled.

Typical applications are cylinder and motor controls for all handling functions as in loading cranes, telescopic handlers, aerial platforms, municipal vehicles, construction machinery, drilling equipment, agricultural and forestry machinery, offshore applications, underground mining.

OVERVIEW PMV

A-SIDE

B-SIDE

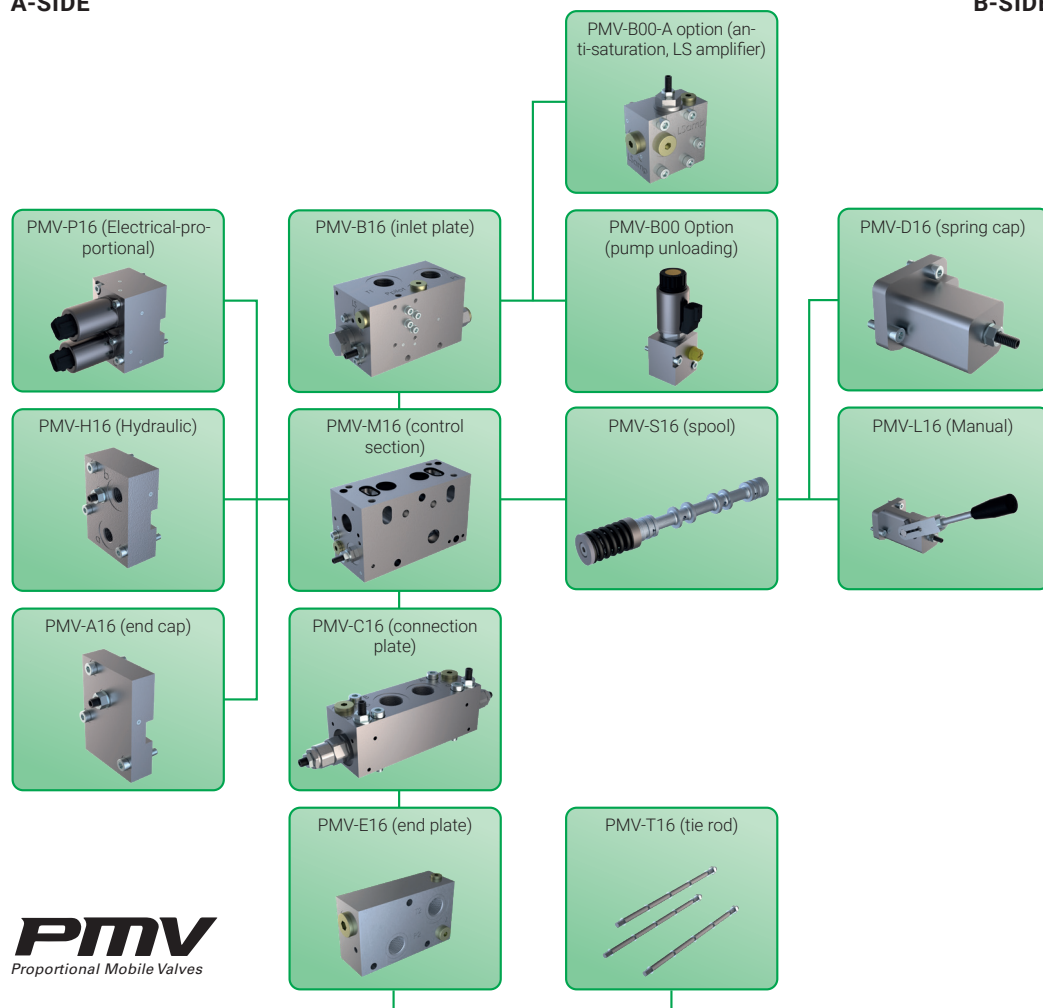

OVERVIEW PMV EXAMPLE UNIT

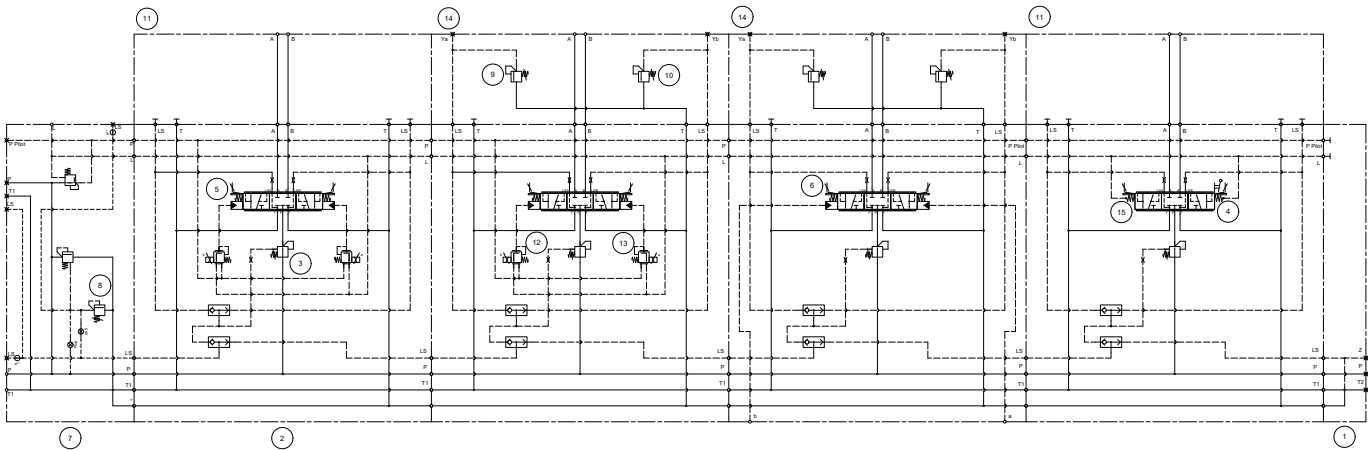

- 1: End plate
- 2: Control section
- 3: delta p setting
- 4: Spring cap with manual actuation
- 5: Spring cap
- 6: Stroke limitation
- 7: Inlet plate
- 8: Input pressure limitation

- 9: LS relief valve A
- 10: LS relief valve B
- 11: Connection plate
- 12: Proportional pressure reducing valve B
- 13: Proportional pressure reducing valve A
- 14: Connection plate with LS pressure reliefs
- 15: End cap

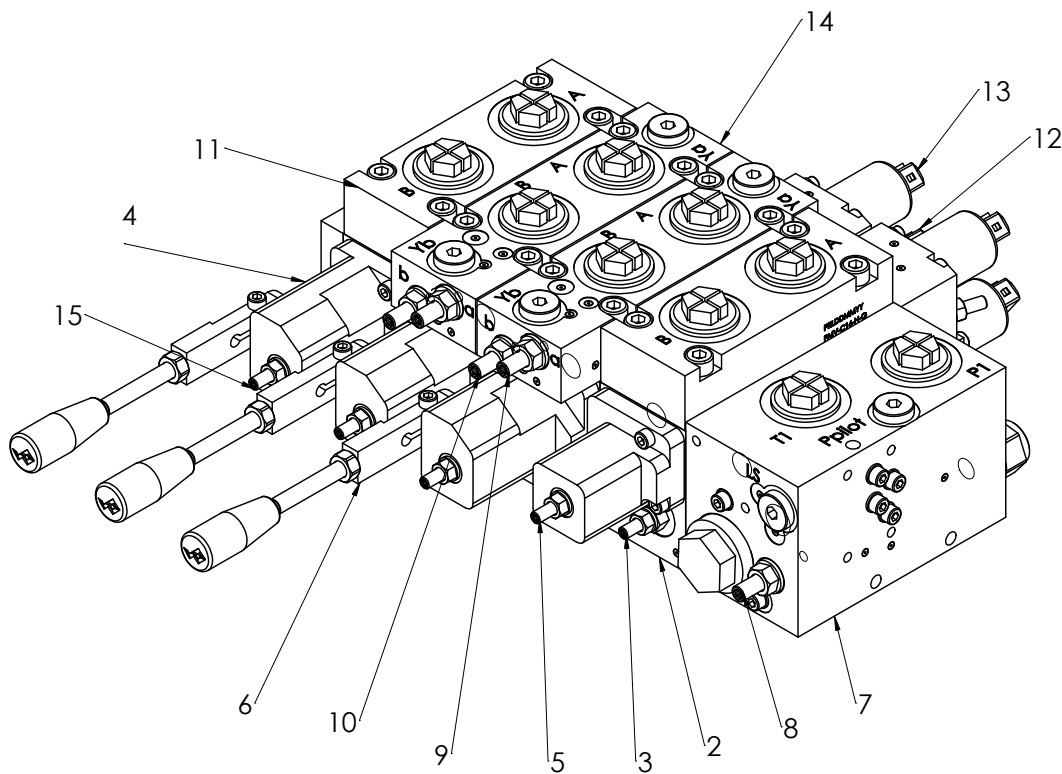

GENERAL SPECIFICATIONS

| | |
|-------------------------------|------------------------------------------|
| Designation | Proportional spool valve |
| Construction type | Sectional design pilot operated |
| Mounting type | Inline mounting Any mounting position |
| Dimension | Nominal size 16 |
| Number of control sections | Max. 12 |
| Temperature range environment | -30...+70 °C |
| MTTFd | 150 years |

ELECTRICAL SPECIFICATIONS

| | |
|-----------------------------------------------------------|-----------------------------------------------------------------------------------------------------------------------------------|
| Nominal voltage | 12 VDC or 24 VDC |
| Type of protection | Connection version D: IP65 Connection version J: IP66 Connection version G: IP67 and IP69K |
| Connection | Connector socket D: DIN, EN175301-803 / ISO 4400 Connector socket J: AMP Junior Timer Connector socket G: Deutsch DT04 – 2P |
| Relative duty factor | 100% DF |
| Dither frequency for proportional solenoids (recommended) | 100 Hz |

SEALING MATERIALS

HNBR as standard, FKM (Viton) as option

ACTUATION

| | |
|----------------------------------------------------------------------------------|----------------------------------------------------------------------------------------------------------------------------------------------------------|
| Possible modes of operation | <ul style="list-style-type: none"> Electrically pilot operated (12V/24V) Hydraulically pilot operated (6-22 bar) Manual |
| Manual override (lever) optional combined with electric and hydraulic actuation. | |

HYDRAULIC SPECIFICATIONS

| | |
|-------------------------------|-------------------------------------------------------------------------------------------------|
| Operating pressure P, A/B | $p_{max} = 420$ bar |
| Tank pressure | $p_{Tmax} = 35$ bar |
| Maximum volume flow Q_{max} | Port P1 or P2: 180 l/min Port P1 and P2: 280 l/min Port A/B: 180 l/min (with compensator) |
| Pressure setting range | 14...420 bar |
| Hysteresis | ≤ 3 % at optimal dither signal |
| Fluid | Mineral oil, other fluids on request |
| Viscosity range | 12 mm ² /s...320 mm ² /s |
| Temperature range fluid | -30...+80 °C (HNBR) -15...+80 °C (Viton) |
| Contamination efficiency | Class 18 / 16 / 13 ISO 4406 |
| Filtration | Recommended filtration grade beta 6...10 ≥ 75 |

SURFACE TREATMENTS K8

- Most external parts are zinc-nickel coated (K8).
- The fixing screws are zinc coated.
- Adjusting screws are in stainless steel.

INLET PLATE PMV-B16

Inlet plate

Plate version

- F For fixed displacement pump
- H For fixed displacement pump high flow
- V For LS pump
- P For LS pump with main relief valve in P

Max. pressure main relief

- 1 p_{max} 100 bar
- 4 p_{max} 420 bar

Port connection

- G Thread in BSP
- S Thread in SAE-ORB

Seal type

- D4 Seals HNBR 90
- D1 Seals Viton

Surface protection

- K8 Zinc-nickel

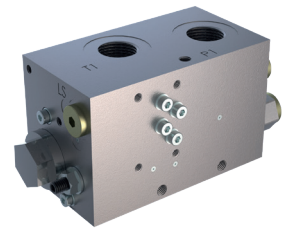

FIXED DISPLACEMENT PUMP

The PMV inlet plate type B16-F/H is used for fixed displacement pumps. This inlet plate includes a 3-way pressure compensator for the recirculation function, as well as a maximum pressure setting. The adjustment range of the maximum pressure setting is 14 to 420 bar. The inlet plate type B16-F is suitable for flows up to 100 l/min with one control section. For higher flow rates, the inlet plate type B16-H is required.

If no control section is actuated, the pump flow recirculates to the tank without pressure.

When one or more control sections are actuated, the highest load pressure signal is fed back to the 3-way pressure compensator, pressurising the pump line.

SCHEME F / H

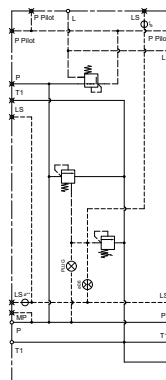

VARIABLE PUMP (LS PUMP)

The PMV inlet plate type B16-V/P is used for load sensing pumps (LS pumps).

The PMV inlet plate of type B16-V has the ports P, T and the LS signal. The LS signal can be adjusted up to 420 bar via the pressure setting.

The type B16-P inlet plate also has a maximum pressure setting in P to provide additional protection for the system.

SCHEME V / P

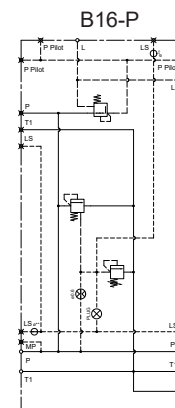
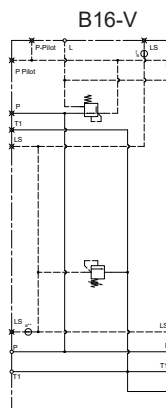

PRESSURE COMPENSATED LS PUMP

The PMV inlet plate type B16-V is used for pressure compensated LS pumps (constant pressure networks).

The inlet plate is used to connect P and T, whereby the LS connection is closed here.

The LS signal can be adjusted to up to 420 bar via the pressure relief.

SCHEME V

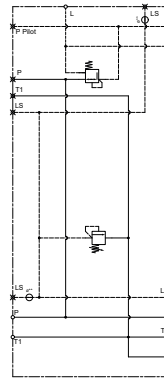

ANTI-SATURATION, LS AMPLIFIER PMV-B00 (OPTION FOR INLET PLATE)

Anti-saturation, LS amplifier



A Anti-saturation and LS amplifier (in combination with V or P inlet plate)

Port connection
G Thread in BSP

Seal type
D4 Seals HNBR 90
D1 Seals Viton

Surface protection
K8 Zinc-nickel

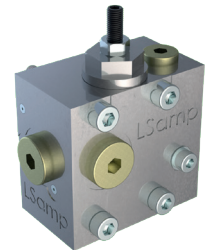

OPTION ANTI-SATURATION, LS AMPLIFIER

The anti-saturation option is used for electrically and hydraulically operated valves.

If insufficient pump flow is provided to the valve block, then the anti-saturation function reduces the feed pressure of the pilot circuit. This enables the simultaneous and load pressure independent operation of the individual functions.

The LS amplifier option amplifies the LS signal in the direction of the pump and compensates for signal losses. This is useful if the LS pump has its own internal pressure relief, which causes LS signal pressure losses. This option can also be used for stability adjustments between pump and valve block.

SCHEME B00-A

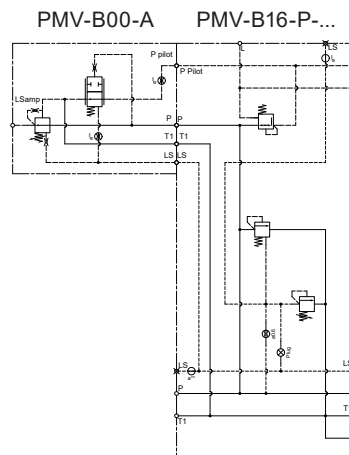

PUMP UNLOADING PMV-B00 (OPTION TO INLET PLATE)

Pump unloading



Pump unloading and electrical-proportional pressure relief

- O Normally open
- C Normally closed
- P Electrical proportional pressure relief
- I Inverse electrical-proportional pressure relief

Voltage

- 12 12 Volt DC
- 24 24 Volt DC

Electrical specifications

- SD Connector socket DIN, EN175301-803 / ISO 4400
- SG Connector socket Deutsch DT04 - 2P

Port connection

- G Thread in BSP

Seal type

- D4 Seals HNBR 90
- D1 Seals Viton

Surface protection

- K8 Zinc-nickel



MAX. PRESSURE FOR PMV-B00

$p_{max} = 350 \text{ bar}$

OPTION ELECTRICAL-PROPORTIONAL PRESSURE SETTING (P / I)

With this function, the maximum pressure of the entire block can be adjusted electrically-proportionally. This function is available in 12V DC and 24V DC.

Limiting current at 50°C : 1320 mA at 12 VDC
660 mA at 24 VDC

OPTION PUMP UNLOADING (O / C)

The pump unloading function can be used as an emergency stop function, for example. The LS signal of all control sections to the tank is unloaded. Both the "normally open" and the "normally closed" version are available. Please note that the stand-by pressure or the pressure in the pump line remains despite the function activation.

The 12VDC respectively 24VDC solenoids have an electrical power of 20 watt.

INSTALLED VALVES

| Type | Designation | Data sheet no. |
|------|-------------------------------------------------|----------------|
| O | Normally open | - |
| C | Normally closed | 1.11-208B |
| P | Electrical-proportional pressure relief | 2.3-539 |
| I | Inverse electrical-proportional pressure relief | 2.3-548 |

SCHEME O / C / P / I

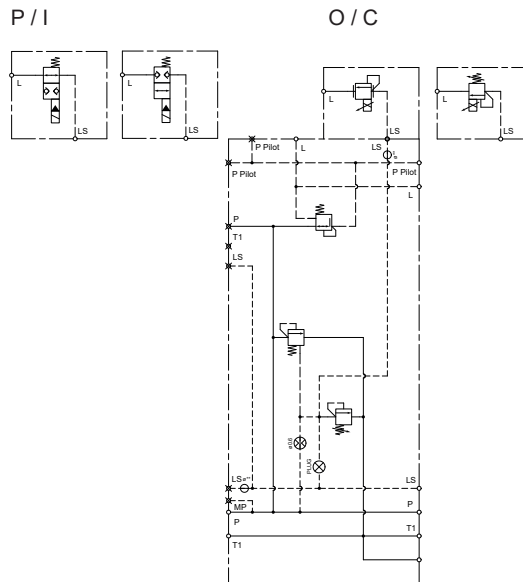

CONTROL SECTION PMV-M16

Control section



Pressure compensator

- A Without pressure compensator
- B With pressure compensator
- C With pressure compensator and non-return valve function

Pressure compensator spring

Nominal volume flow rate Q_N see spool kit PMV-S16

- S Standard flow spring (100% flow)
- H High flow spring (120% flow)
- B Boost flow spring (180% flow)
- L Low flow spring (56% flow)
- N No pressure compensator (for option A only, 200% flow)

Seal type

- D4 Seals HNBR 90
- D1 Seals Viton

Surface protection

- K8 Zinc-nickel

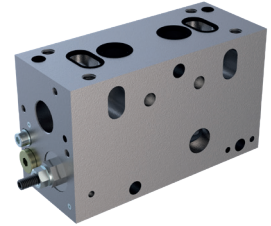

By selecting a pressure compensator in the control section, the flow rate is regulated individually and load-independently per function. Each control section can be individually configured with a wide variety of modules. The actuation functions "electrical", "hydraulic" and "manual" can be added to the control section to guarantee high flexibility of the variants. A manual override function is also possible for the electrical and hydraulic operating modes.

The complete PMV-16 control unit can be constructed from up to 12 different control sections.



NOTE!

B (Boost flow spring), the pressure drop of the compensator cannot be adjusted.

CONTROL SECTION M16-A

The M16-A unit does not have a pressure compensator.

SCHEME A

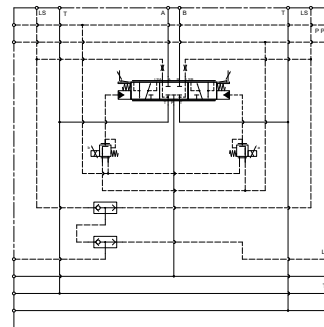

CONTROL SECTION M16-B / C

The units M16-B / C are equipped with a pressure compensator. The M16-C variant is additionally equipped with a non-return valve in the supply line to the pressure compensator to ensure the pressure independence of the individual control sections. The non-return function prevents consumer oil from flowing back into the pump channel.



NOTE!

Max flow 100 l/min across control section M16-C.

The pressure compensation of the pressure compensator can be selected to increase or decrease the flow compared to the nominal value of the spool. The delta p of the pressure compensator is adjustable via an adjusting screw on the outside of the valve.

SCHEME B / C

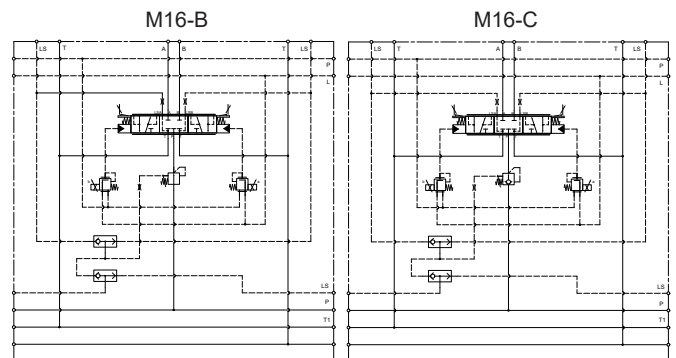

Tightening torque delta p adjusting screw: 10 Nm

ELECTRICAL-PROPORTIONAL PMV-P16 FOR CONTROL SECTION

Electrical-proportional



Voltage

12 12 Volt DC
24 24 Volt DC

Electrical specifications

SJ Connector socket AMP Junior - Timer
SG Plug socket Deutsch DT04 - 2P

Seal type

D4 Seals HNBR 90
D1 Seals Viton

Surface protection

K8 Zinc-nickel

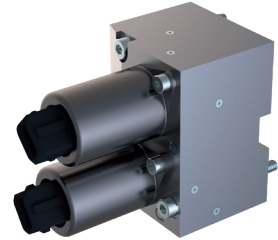

ELECTRICAL-PROPORTIONAL

The electrically-proportionally actuated version uses an electrical control module that controls the main spool of the control section via 2 proportional pressure reducing valves.

The pressure reducing valves are available in 12VDC and 24 VDC with different connector versions.

The control module PMV-P16 can be used optionally in combination with the spring cap PMV-D16 or the manual override PMV-L16.

The cap contains an adjustment screw for flow limitation.

Tightening torque of the fastening screws: 6 Nm.
Tightening torque of the nut with flow limitation: 10 Nm

SCHEME

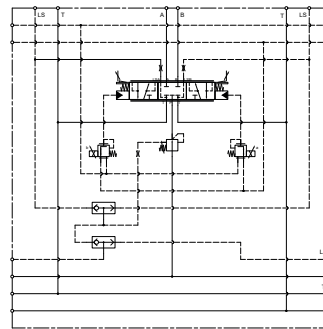

| | |
|--------------------------|----------------------|
| Limiting current at 50°C | 1500 mA at 12 VDC |
| | 750 mA at 24 VDC |
| Solenoid resistance | 4.72 Ω ±5% at 12 VDC |
| | 20.8 Ω ±5% at 24 VDC |

HYDRAULICAL PMV-H16 FOR CONTROL SECTION

Hydraulical

PMV - H16 - - - K8

Port connection
G Thread in BSP

Seal type
D4 Seals HNBR 90
D1 Seals Viton

Surface protection
K8 Zinc-nickel

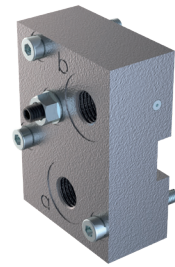

HYDRAULICAL

In the hydraulically actuated version, instead of the electrical-proportional control module, a hydraulic control module is used, which contains ports (A, B) for the hydraulic joysticks.

The port dimension is designed in 1/4"BSP.

The pilot pressure range of the hydraulic joysticks used should be 6 to 22 bar.

The control module PMV-H16 can be used optionally in combination with the spring cap PMV-D16 or the manual override PMV-L16.

The cap contains an adjustment screw for flow limitation.

Tightening torque of the fastening screws: 6 Nm.
Tightening torque of the nut with flow limitation: 10 Nm

SCHEME

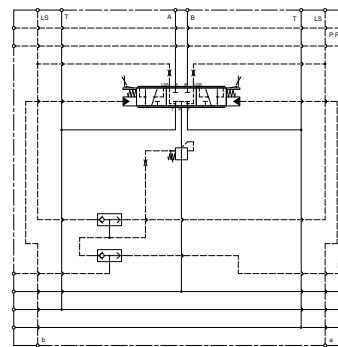

SPRING CAP PMV-D16 FOR CONTROL SECTION

Spring cap

PMV - D16 - - K8

Seal type

D4 Seals HNBR 90

D1 Seals Viton

Surface protection

K8 Zinc-nickel

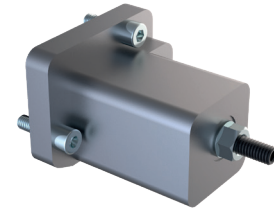

SPRING CAP D16

The spring cap D16 is used for the electrical and hydraulic operating form. The cap is used to hold the spring assembly and contains an adjustment screw for flow limitation.

Tightening torque of the fastening screws: 6 Nm.

Tightening torque of the nut with flow limitation: 10 Nm

MANUAL PMV-L16 FOR CONTROL SECTION

Manual

PMV - L16 - - K8

Seal type

D4 Seals HNBR 90

D1 Seals Viton

Surface protection

K8 Zinc-nickel

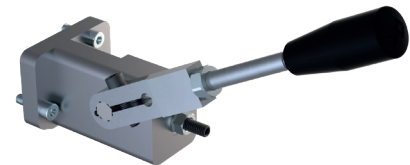

MANUAL L16

The manual cap L16 is used for the manually operated function only or the manual override function.

The cap is used to hold the spring assembly and contains an adjustment screw for flow limitation.

Tightening torque of the fastening screws: 6 Nm.

Tightening torque of the nut with flow limitation: 10 Nm

Lever force: 26 N

Centre position lever: Standard horizontal, can optionally be mounted rotated by 30° in both directions.

Lever stroke range for full deflection: +/- 30°

MANUALLY OPERATED PMV-A16 FOR CONTROL SECTION

End cap

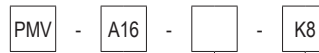

Seal type

D4 Seals HNBR 90

D1 Seals Viton

Surface protection

K8 Zinc-nickel

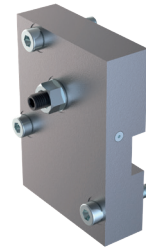

MANUALLY ACTUATED

For fully manual control sections, the end cap A16 is used in combination with the manual cap L16.

The cap contains an adjustment screw for flow limitation.

Tightening torque of the fastening screws: 6 Nm.

Tightening torque of the nut with flow limitation: 10 Nm

SCHEME

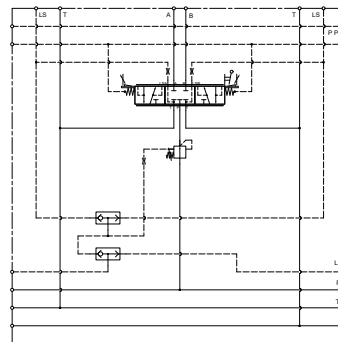

SPOOL PMV-S16

Spool



Symbol Spool

ACB
ADB

Ratio

1 1:1
2 2:1 (high flow in A)

Nominal volume flow rate Q_N

100 100 l/min
075 75 l/min
050 50 l/min
030 30 l/min

Spring assembly

H Manual control only (A16 with L16)
F Manual control only, with friction brake (A16 with L16)
E Electrical / hydraulic control (P16 or H16 with D16)
O Electrical / hydraulic control – manual override (P16 or H16 with L16)

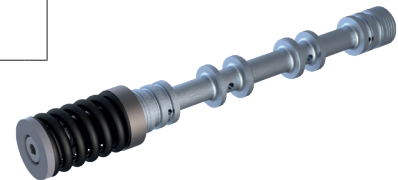

The various spool sets consist of spool and spring assembly and can be mounted in any variation in the honed bore of the control section due to the high production accuracy.

In order to cover the entire volume flow range, there are various spools with corresponding control edges.

Spools with a flow ratio of 1:1, but also spools with a flow ratio of 2:1 can be configured for the corresponding cylinder applications.

The PMV programme provides a wide range of spool types. The most common spools are available with closed or open centre position, but special shapes are also available. Flexibility is further increased with the choice of pressure compensator delta p setting in the control section to precisely set the required flow rate.

SYMBOL

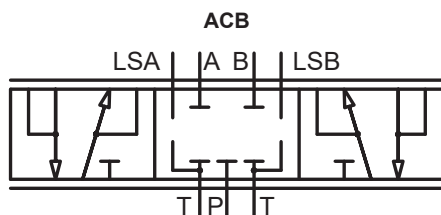

Spool with closed centre position

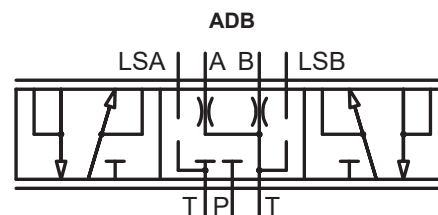

Spool with open centre position
A / B 20 % open to the tank

FRICTION BRAKE

There are detent positions in the middle and also in the end of each stroke position (center position, fully open on "a" and fully open on "b"). In between, the hand lever can be positioned freely on each angle position and then the lever will stay in this position.

CONNECTION PLATE PMV-C16

Connection plate

PMV - C16 - - - - - - - K8

- N A/B port only
- H A/B port & LS relief
- C A/B port & LS relief & optional cartridge

Max. setting LS pressure relief

- N Without (N plate only)
- 1 100 bar
- 4 420 bar

Cartridge options side A

- N No options (If C no cartridge mounted)
- T Shock suction function
- A Pressure relief in user port, <280bar
- B Pressure relief in user port, >280bar
- S Suction function

Cartridge options side B

- N No options (If C no cartridge mounted)
- T Shock suction function
- A Pressure relief in user port, <280bar
- B Pressure relief in user port, >280bar
- S Suction function

Port connection

- G Thread in BSP
- S Thread in SAE-ORB

Seal type

- NN No seals (N plate only)
- D4 Seals HNBR 90
- D1 Seals Viton

Surface protection

- K8 Zinc-nickel

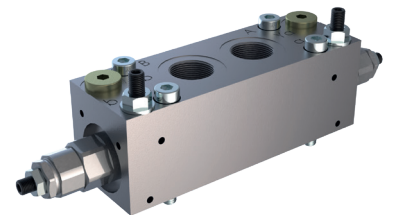

CONNECTION PLATE C16-N

The basic connecting plate type C16-N has only the ports A and B.

SCHEME N

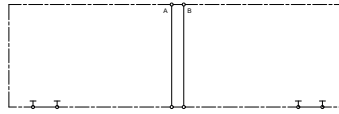

CONNECTION PLATE C16-H

LS pressure relief valves are integrated in the connection plate type C16-H on the A and B sides.

SCHEME H

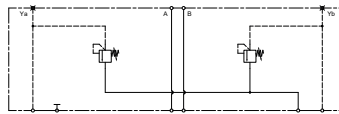

CONNECTION PLATE C16-C

The connection plate type C16-C is an extended design.

In addition to the LS pressure relief valves, this plate can be extended with additional cartridges for various functions. Possible variants of built-in cartridges are the suction function (S), the pressure relief function (B) and the shock suction function (T). The cartridges can be used independently on the A and B sides.

These additional valves in A and B act directly on the working port. This is in contrast to the LS pressure limitations, which act on the LS signal.

SCHEME C

C-TT

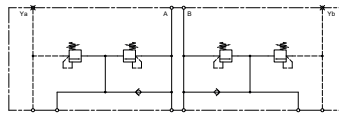

C-BB

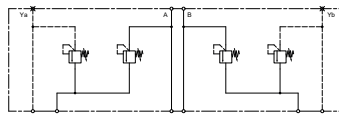

C-SS

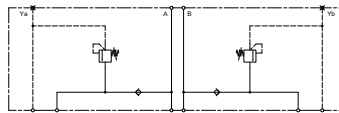

SURFACE TREATMENTS

Cartridges for PMV-C16-C are zinc coated.

END PLATE PMV-E16

End plate



Plate version

- A Small end plate without ports
- B With additional P2 and T2 port
- C With Z port, with additional P2 and T2 port

Port connection

- G Thread in BSP
- S Thread in SAE-ORB
- N No ports (A plate only)

Seal type

- NN No seals (A plate only)
- D4 Seals HNBR 90
- D1 Seals Viton

Surface protection

- K8 Zinc-nickel



SMALL END PLATE E16-A

The PMV end plate type E16-A only contains the LS pressure relief of the shuttle valve cascade.



NOTE!

Using the reduction inlet plate PMV-R22, it is necessary to have on both sides the (wide) endplate. PMV-E22-B/C (size 22 side) and PMV-E16-B/C (size 16 side)

SCHEME A



WIDE END PLATE E16-B

The PMV end plate type E16-B includes an extra P and T port in addition to the LS pressure relief of the shuttle valve cascade.

SCHEME B

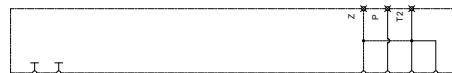

WIDE END PLATE E16-C

The PMV end plate type E16-C includes an extra P and T port.

In addition, the LS signal of a downstream valve unit can be connected to the upstream valve unit via the Z port (series connection of two blocks).

SCHEME C



Tie rods

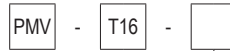

- S01 Tie rod kit small, end plate A, 1 section
- S02 Tie rod kit small, end plate A, 2 sections
- S03 Tie rod kit small, end plate A, 3 sections
- S04 Tie rod kit small, end plate A, 4 sections
- S05 Tie rod kit small, end plate A, 5 sections
- S06 Tie rod kit small, end plate A, 6 sections
- S07 Tie rod kit small, end plate A, 7 sections
- S08 Tie rod kit small, end plate A, 8 sections
- S09 Tie rod kit small, end plate A, 9 sections
- S10 Tie rod kit small, end plate A, 10 sections
- S11 Tie rod kit small, end plate A, 11 sections
- S12 Tie rod kit small, end plate A, 12 sections

- W01 Tie rod kit wide, end plate B/C, 1 section
- W02 Tie rod kit wide, end plate B/C, 2 sections
- W03 Tie rod kit wide, end plate B/C, 3 sections
- W04 Tie rod kit wide, end plate B/C, 4 sections
- W05 Tie rod kit wide, end plate B/C, 5 sections
- W06 Tie rod kit wide, end plate B/C, 6 sections
- W07 Tie rod kit wide, end plate B/C, 7 sections
- W08 Tie rod kit wide, end plate B/C, 8 sections
- W09 Tie rod kit wide, end plate B/C, 9 sections
- W10 Tie rod kit wide, end plate B/C, 10 sections
- W11 Tie rod kit wide, end plate B/C, 11 sections
- W12 Tie rod kit wide, end plate B/C, 12 sections



TIE RODS

For the assembly of complete PMV-16 control blocks, 2 different tie rod kits are available, which are used depending on the type of end plate used.

The tie rod kits each consist of 3 pcs. tie rods and M8 nuts with plastic caps.

The tie rods are in Cr-steel material and the M8 nuts are Zinc-nickel coated.

PERFORMANCE SPECIFICATIONS

Oil viscosity = 30 mm²/s

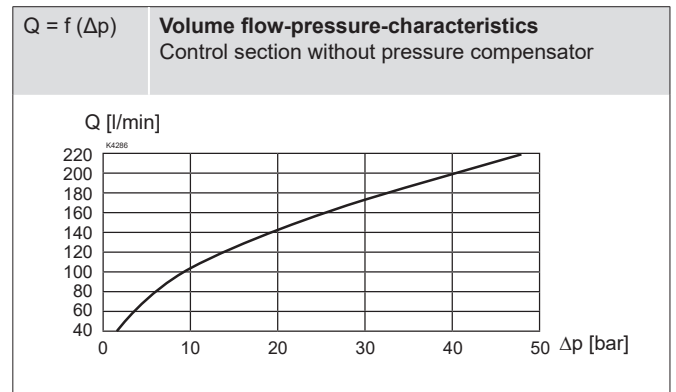
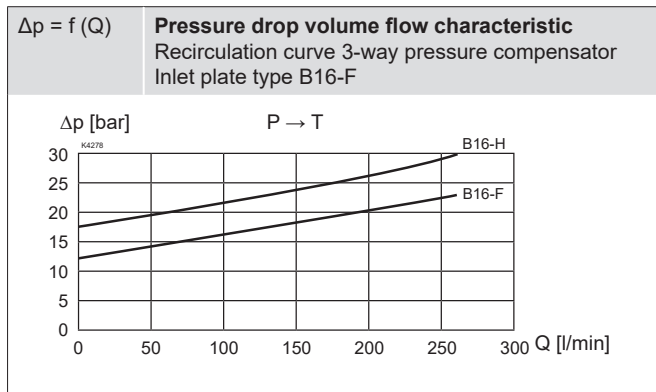
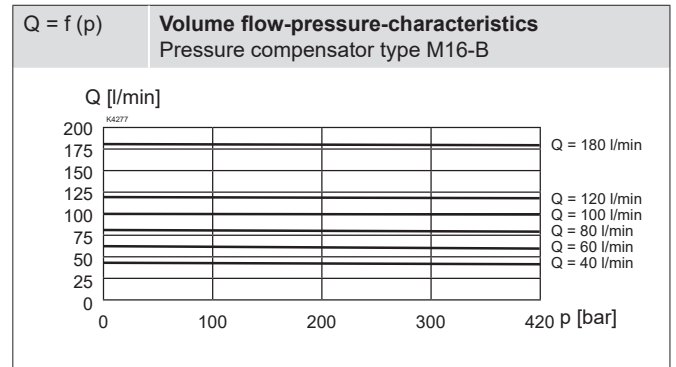
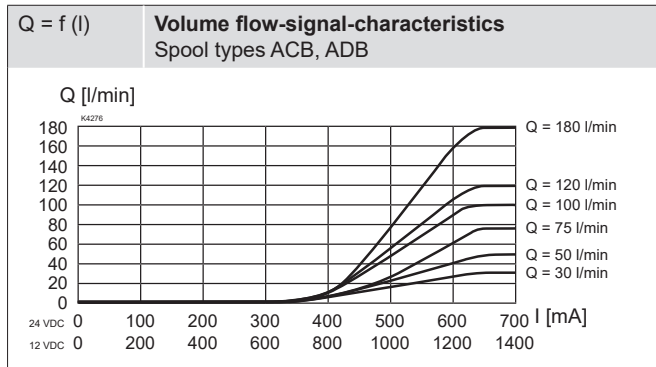

DIMENSIONS

Dimension drawing

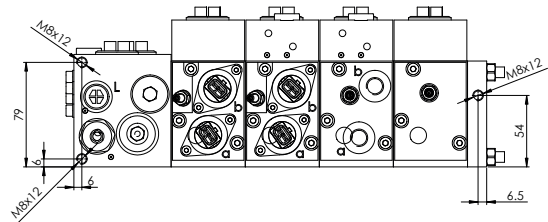
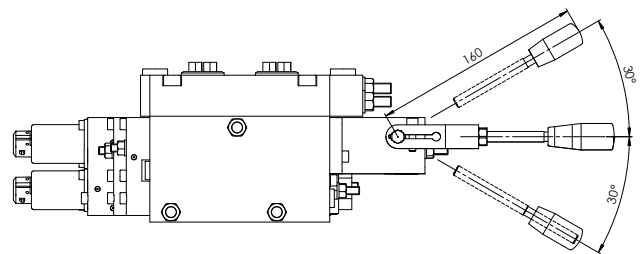
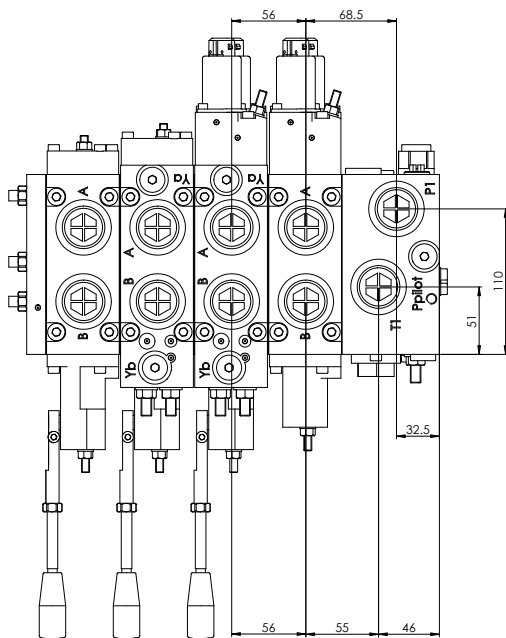
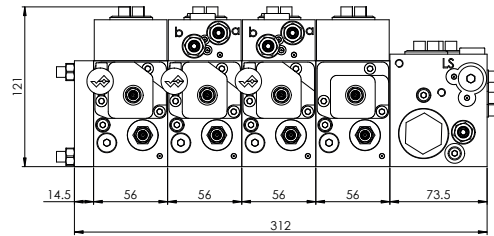
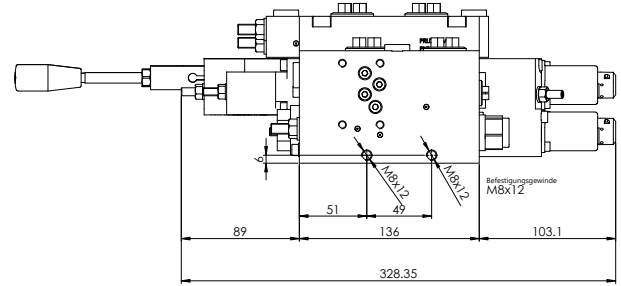
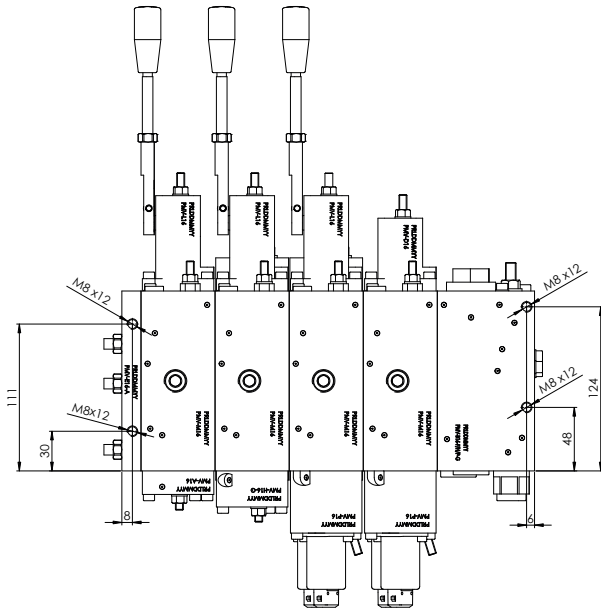

ASSEMBLY OF THE CONTROL UNIT

Various M8x12 mounting threads are available for the assembly of the control unit:

Inlet plate:
 PMV-B16: 6 x mounting thread M8x12

End plate:
 PMV-E16: 3 x mounting thread M8x12

HYDRAULIC PORT

| Port | BSP | SAE ORB |
|----------------|-------|---------|
| Port P, T | G3/4" | 12 |
| Port A, B | G3/4" | 12 |
| Port LS | G1/4" | 6 |
| Port L (Drain) | G1/8" | 4 |
| Port Ya, Yb | G1/4" | 6 |
| Port Z | G1/4" | 6 |

ASSEMBLY INSTRUCTIONS

| | |
|-------------------|-------------------------------------------------------------------------------------------------------------------|
| Type of mounting | Control unit in sandwich construction with threaded connection. Mounting holes on the inlet and end plate M8 x 12 |
| Mounting position | any |
| Tightening torque | M = 25 Nm |
| Tie rods | |

WEIGHTS PER PMV MODULE

| | |
|-------------------|--------|
| PMV-B16-F / H / P | 5,4 kg |
| PMV-B16-V | 4,6 kg |
| PMV-M16 | 3,5 kg |
| PMV-P16 | 1,3 kg |
| PMV-H16 | 0,7 kg |
| PMV-D16 | 0,3 kg |
| PMV-L16 | 0,6 kg |
| PMV-A16 | 0,4 kg |
| PMV-S16 | 0,2 kg |
| PMV-C16-N | 1,4 kg |
| PMV-C16-H | 1,9 kg |
| PMV-C16-C | 2,8 kg |
| PMV-E16-A | 1,0 kg |
| PMV-E16-B / C | 3,2 kg |

WEIGHTS PER PMV MODULE

| | |
|-------------|--------|
| PMV-B00-A-G | 1,0 kg |
| PMV-B00-I-G | 1,4 kg |
| PMV-B00-P-G | 1,4 kg |
| PMV-B00-O-G | 0,8 kg |
| PMV-B00-C-G | 0,7 kg |

WEIGHTS PER TIE ROD KIT

| | |
|-------------|--------|
| PMV-T16-W01 | 0,2 kg |
| PMV-T16-W02 | 0,2 kg |
| PMV-T16-W03 | 0,3 kg |
| PMV-T16-W04 | 0,4 kg |
| PMV-T16-W05 | 0,4 kg |
| PMV-T16-W06 | 0,5 kg |
| PMV-T16-W07 | 0,6 kg |
| PMV-T16-W08 | 0,6 kg |
| PMV-T16-W09 | 0,7 kg |
| PMV-T16-W10 | 0,7 kg |
| PMV-T16-W11 | 0,8 kg |
| PMV-T16-W12 | 0,9 kg |

WEIGHTS PER TIE ROD KIT

| | |
|-------------|--------|
| PMV-T16-S01 | 0,1 kg |
| PMV-T16-S02 | 0,2 kg |
| PMV-T16-S03 | 0,2 kg |
| PMV-T16-S04 | 0,3 kg |
| PMV-T16-S05 | 0,4 kg |
| PMV-T16-S06 | 0,4 kg |
| PMV-T16-S07 | 0,5 kg |
| PMV-T16-S08 | 0,6 kg |
| PMV-T16-S09 | 0,6 kg |
| PMV-T16-S10 | 0,7 kg |
| PMV-T16-S11 | 0,8 kg |
| PMV-T16-S12 | 0,8 kg |