

Table of Contents

1	Product Description	2
1.1	Application	2
1.2	Mounting location (Recommendation)	2
2	Function	3
2.1	Characteristics	3
3	Technical Data	4
4	Ordering Information	5
4.1	Type Code	5
4.2	Versions currently available	5
5	Description of Characteristics in Accordance with Type Code	6
5.1	Characteristic 1: Variant.....	6
5.2	Characteristic 2: Connections	6
5.3	Characteristic 3: Input volume flow	6
5.3.1	Pressure loss in relation to input volume flow: P to A	6
5.3.2	Characteristic: Accuracy at maximum output volume flow: P - H	6
5.4	Characteristic 4: Maximum permissible pressure	7
5.5	Characteristic 5: Actuation	7
5.6	Characteristic 6: Hydraulic system.....	7
5.7	Characteristic 7: Output volume flow	7
5.8	Characteristic 8: Check valve, throttling check valve.....	7
6	Installation	8
6.1	General remarks	8
6.2	Connection suggestion	8
6.3	Installation - Space	8
6.3.1	Tightening torque	9
6.4	Setting the output flow rate	9
6.5	Setting the pressure relief for the attachment	10
6.6	Dimensions	10
7	Notes, Standards and Safety Requirements	11
7.1	General remarks	11
7.2	Standards.....	11
8	Accessories	11

1 Product Description

The flow control valve is a 2-way or 3-way flow controller (pressure compensator) for flows up to 200 l / min and enables the operation of additional single-acting consumers. The attachment can be operated simultaneously to the normal machine functions. The volume flow and pressure to the auxiliary function is independent of the pressure and the volume flow of the main functions in the machine.

1.1 Application

Flow control valves of this product group are used to supply single acting hydraulic consumers, such as hydraulic motors, hydraulic hammers, etc. with a controlled flow rate. This volume flow is divided of a main volume flow by means of the flow control valve.

1.2 Mounting location (Recommendation)

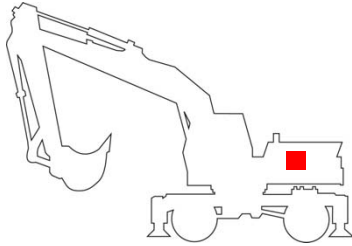

The flow control valve is mounted in open center systems in the flow between the pump and the main control unit.

In closed center systems, it is recommended that the flow control valve be installed as a bypass between the pump and the main control system.

2 Function

The flow control valve can be used in two different modes :

As a 3- way flow control valve

In this mode the valve is drained by the entire pump flow (P to A or P to A + H). When not activated, the entire flow is available at port A and is used for the operation of the main functions of the machine. When enabled, a partial volume flow is divided from the main volume flow and routed to the output H. Partial flow and main flow are independent of each other (pressure compensator function).

The valve size to choose for a special application is determined by the maximum volume flow of the pump and the associated pressure loss in the valve (see 4.3.1 Pressure drop as a function of the input flow : P to A).

As a 2- way flow control valve

In this mode, the valve is connected by means of a T-piece to the main pump line. The flow control valve demands volume flow from the pump in the same manner as the main control valve does. A corresponding load signal (LS) is provided in the valve. The requested flow rate is regulated by the flow control valve and delivered to the additional consumer (P to H). A residual flow does not exist because only the amount the additional consumer needs is requested from the pump. The output port A therefore is closed .

The valve size is determined by the flow demand of the additional consumer.

In both modes, the attachment can be activated electrically or hydraulically or remain permanently switched on. The quantity of the volume flow to the attachment can be set manually by the user. The maximum pressure limit for the additional load is set by the user as well.

The pressure relief is based on the principle of pressure cut-off and thus controls the volume flow as far back until the set maximum pressure is not exceeded anymore.

On the consumer connection H a preloaded check valve or a throttling check valve can be installed. This check valve prevents on one hand influences of the consumer to the control of the flow control valve and on the other hand provides that the flow control valve is always preloaded as required (>8bar) for a proper operation even with consumers with a very low initial pressure.

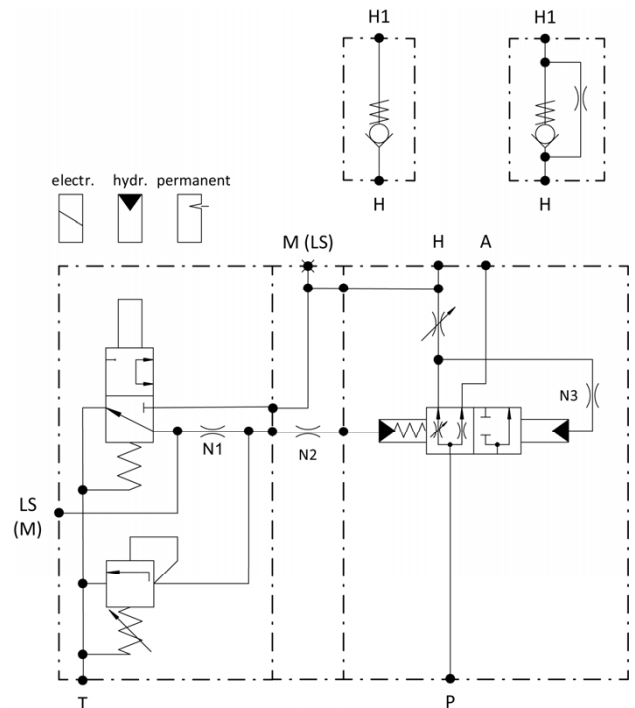

2.1 Characteristics

- Precision flow distribution
- Wide range for adjusting the usable priority flow
- Protection against pressure loss of the consumer independently of flow rate based on the pressure cut-off principle
- Small pressure loss in free-flow

3 Technical Data

	Units	Version 55 l/min	Version 100 l/min	Version 200 l/min
Installation position		Any		
Weight, kg	kg	5.4	9	10.2
Max. input pressure	bar	320	420	
Adjustable attachment pressure	bar	100-320		
Adjustable output flow	l/min	12-55	12-100	30-200
Accuracy of output flow	%	+/-12%	+/-12%	+/-10%
Maximum tank pressure	bar	1 bar (recommended)		
Input flow rate	l/min	55	100	200
Hydraulic fluid		Mineral oil (HL, HLP) conforming with DIN 51524, other fluids upon request		
Hydraulic fluid pressure range	°C	-20 – +80 °C		
Ambient temperature	°C	< +50 °C		
Viscosity range	mm ² /s	2.8 – 500		
Contamination grade		Filtering conforming with NAS 1638, class 9, with minimum retention rate $\beta_{10} \geq 75$		
Supply voltage	VDC	12 or 24		
Voltage tolerances	%	+/- 10		
Power consumption:	W	33		
I nominal:	A	2.9 at 12 VDC, 1.4 at 24 VDC		
Power-on time:	%	100		
Protection class according to DIN 40050:		IP 65		
Current supply:		Device socket for ISO 4400 angle connector or Junior Timer plug connector		

4 Ordering Information

4.1 Type Code

FC1 00	1N 01			420 04			01 07	
00	Product group	Current control valve for simple-actuation applications						FC1
01	Variant	Standard variant						1N
02	Connections	Pump (P), output (A), attachment	55 l/min	G 1/2" – ISO 1179-1				03D
			100 l/min	M27x2 – ISO 9974				00H
			200 l/min	SAE 3/4" - CODE 62				05C
03	Eingangsvolumenstrom	l/min	55 l/min				055	
			100 l/min				100	
			200 l/min				200	
04	Max. permissible pressure	420 bar (at 55l/min Version 320 bar)					420	
05	Actuation	Hydraulic (p< 50 bar)					HYS03B	
		Electrical switching 12 VDC – connection via ISO 4400 angle plug connection					12S001	
		Electrical switching 12 VDC – connection via Junior Timer plug					12S002	
		Electrical switching 24 VDC – connection via ISO 4400 angle plug connection					24S001	
		Electrical switching 24 VDC – connection via Junior Timer plug					24S002	
Hydraulic (p< 50 bar)					000000			
06	Hydraulic system	2-way flow controller – suitable for closed center systems (load-sensing systems)					CC	
		3-way flow controller – suitable for open center systems (throttle, NFC systems, etc.)					OC	
07	Output volume flow	Adjustable by user					001	
08	Check valve (CVS) Throttling Check Valve (TCV)		Check valve ID number	55 l/min	100 l/min	200 l/min		
		No CVS	N/A	■	■	■	00	
		CVS 15L	424.071.333.9	■			01	
		CVS 25S	427.071.319.9			■	02	
		CVS 18L	426.072.303.9		■		04	
		CVS M27x2	426.072.306.9		■		16	
		TCV 15L	424.071.306.9	■			11	
		TCV 20S	426.072.301.9		■		13	
TCV 25S	427.071.301.9			■	14			

XXX – Permanent preset characteristics XXXX – Characteristics adjustable by customer
 ■ available ○ not available

4.2 Versions currently available

The versions listed below are available as standard. Further versions as part of the options given on the type code can be configured upon request.

Designation	Type Code	Part No.
FC1-1N G1/2 55LPM LS 320BAR 24VDC CVS15L	FC1 -1N -03D -050 -320 -24S001 -CC -001 -01	234.332.225.9
FC1-1N G1/2 55LPM 320BAR 24VDC TRV15L	FC1 -1N -03D -050 -320 -24S001 -OC -001 -01	234.332.226.9
FC1-1N M27X2 100LPM 320BAR 24VDC TCV20S	FC1 -1N -00H -100 -420 -24S001 -OC -001 -13	235.332.222.9
FC1-1N M27X2 100LPM LS 320BAR 24VDC CVS18L	FC1 -1N -00H -100 -420 -24S001 -CC -001 -04	235.332.556.9
FC1-1N SAE3/4 CD62 200LPM 420BAR 24VDC NOCV	FC1 -1N -05C -200 -420 -24S001 -OC -001 -00	236.364.734.9
FC1-1N SAE3/4 CD62 200LPM 420BAR 24VDC TCV25S	FC1 -1N -05C -200 -420 -24S001 -OC -001 -14	236.364.735.9
FC1-1N SAE3/4 CD62 200LPM LS 420BAR 24VDC CVS25S	FC1 -1N -05C -200 -420 -24S001 -CC -001 -02	236.364.736.9
FC1-1N SAE3/4 CD62 200LPM 420BAR 24VDC TCV25S	FC1 -1N -05C -200 -420 -24S002 -OC -001 -14	236.364.738.9
FC1-1N SAE3/4 CD62 200LPM 420BAR 24VDC NOCV	FC1 -1N -05C -200 -420 -24S002 -OC -001 -00	236.364.740.9
FC1-1N SAE3/4 CD62 200LPM LS 420BAR 24VDC CVS25S	FC1 -1N -05C -200 -420 -24S002 -CC -001 -02	236.364.741.9
FC1-1N SAE3/4 CD62 200LPM 420BAR NOCV	FC1 -1N -05C -200 -420 -000000 -OC -001 -00	236.064.734.9

5 Description of Characteristics in Accordance with Type Code

5.1 Characteristic 1: Variant

Standard, 55 l/min, 100 l/min, 200 l/min

5.2 Characteristic 2: Connections

		Version 55 l/min	Version 100 l/min	Version 200 l/min
	A, P	G ½	M27x2	SAE ¼" Code62
	H	G ½	M27x2	1 5/16" – 12UN
	M	G ¼ (ISO 1179-1)		
	T	G ¼ (ISO 1179-1)		
	LS	8S (ISO 8434-1)		
	MH	G ¼ (ISO 1179-1)		

	SAE size	Max. working pressure [bar]	A	B
	SAE CODE 62			
	¾"	420	23,8	50,8

5.3 Characteristic 3: Input volume flow

Nominal input volume flow in l/min.

55 Nominal flow 55 l/min
100 Nominal flow 100 l/min
200 Nominal flow 200 l/min

5.3.1 Pressure loss in relation to input volume flow: P to A

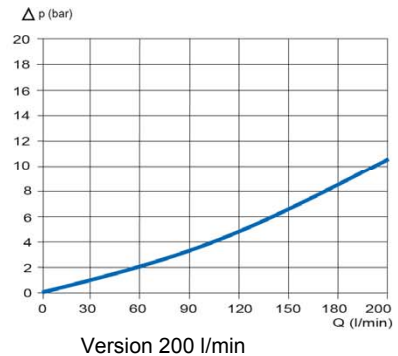
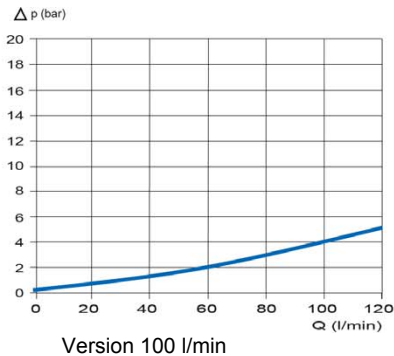
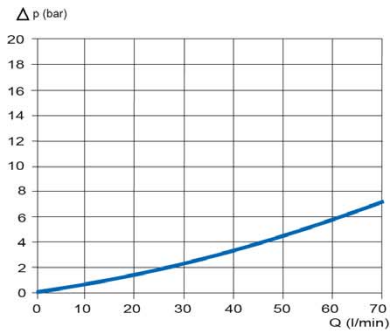

5.3.2 Characteristic: Accuracy at maximum output volume flow: P - H

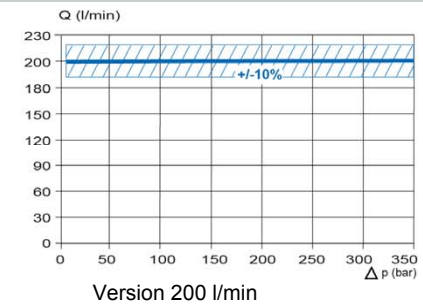
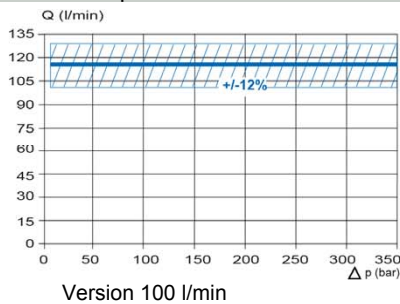
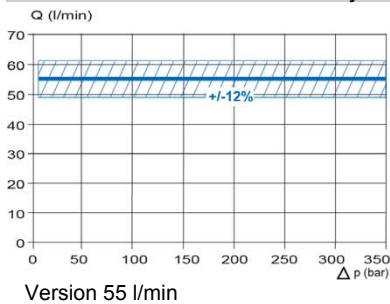

5.4 Characteristic 4: Maximum permissible pressure

The operating pressure of the valve at input P and output A must not exceed 420 bar for all versions.

The operating pressure at output H (attachment) is limited by means of a pressure cut-off valve and must not exceed 320 bar.

5.5 Characteristic 5: Actuation

The valve is actuated electrically or hydraulically, and switches in each case. Different electrical connector plugs are available. The supply voltage can be set to either 12 VDC or 24 VDC.

For permanent operation, a stop screw can be installed.

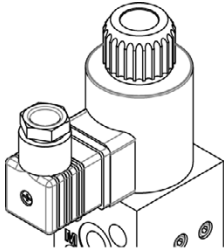

Device socket for angle connector

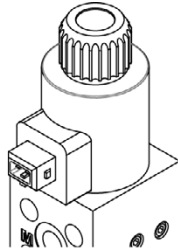

Junior Timer plug-in connector

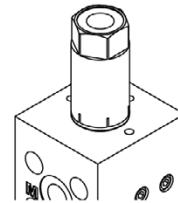

Hydraulic actuation

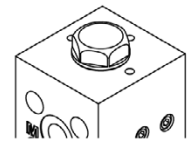

Permanent operation

5.6 Characteristic 6: Hydraulic system

CC hydraulic system

On valves which are pre-fitted for closed center systems (Option: CC, 2-way flow controller) (bypass installation), output line A is closed off and a connection is provided for output LS. This option is only available upon request (see type code). This installation enables the parallel operation of applications, but has energy disadvantages.

OC hydraulic system

On valves which are pre-fitted for open center systems (Option: OC, 3-way flow controller), output line A is open and the LS connection is closed off. In this design, the remainder of the input flow is led onward. Parallel application operation is not possible.

5.7 Characteristic 7: Output volume flow

Data for presetting the flow rate to the attachment.

Here: 001 = Adjustable by user

The user must apply individual flow and pressure limit settings before starting up the valve. For settings, see 6.5

5.8 Characteristic 8: Check valve, throttling check valve

Information on which check valve (CVS) or throttle check valve (TCV) is used in the three versions of the flow control valve.

Version 55 l/min

CVS15L (recommended for Load-Sensing-Systems)

TCV15L

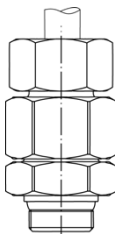

G1/2

Version 100 l/min

CVS18L (recommended for Load-Sensing-Systems)

TCV20S

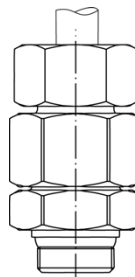

M27x2

Version 200 l/min

CV25S (recommended for Load-Sensing-Systems)

TCV25S

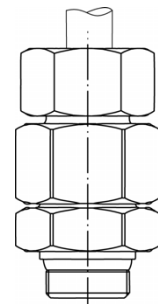

1 5/16 – 12 UN

6 Installation

6.1 General remarks

- Observe all installation and safety information of the construction machine manufacturer.
- Only technically permitted changes are to be made on the construction machine.
- The user has to ensure that the device is suitable for the respective application.
- Application exclusively for the range of application specified by the manufacturer.
- Before installation or dismantling, the hydraulic system is to be depressurized.
- Settings are to be made by qualified personnel only.
- May only be opened with the approval of the manufacturer, otherwise the warranty is invalidated.

6.2 Connection suggestion

Installation in an open center system

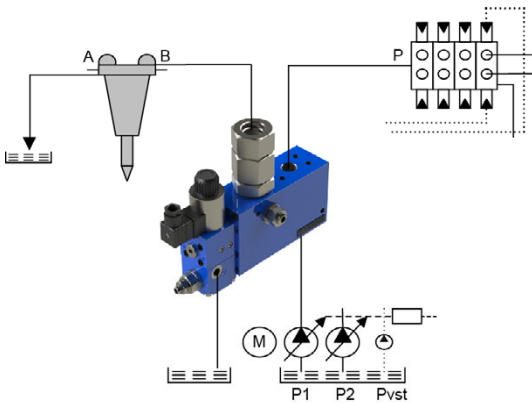

Installation in a closed center system

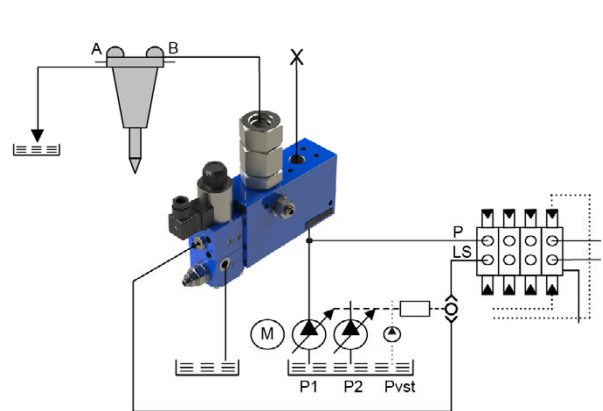

6.3 Installation - Space

- Observe the meaning of the connection.
- Observe the strength category and torque of the clamp bolts.
- Do not damage seals and flange surfaces.
- Vent the hydraulic system.
- Ensure that the surface of the support element is level.
- Ensure that the valve is not bent due to installation.

55 l/min

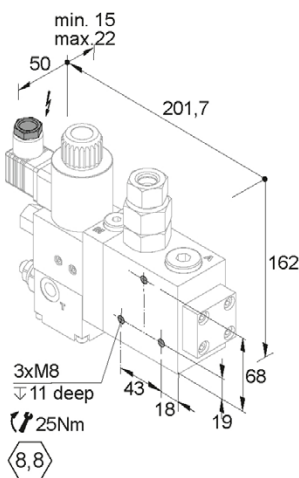

100 l/min

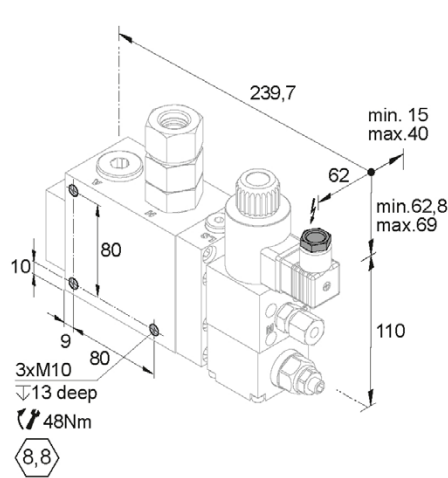

200 l/min

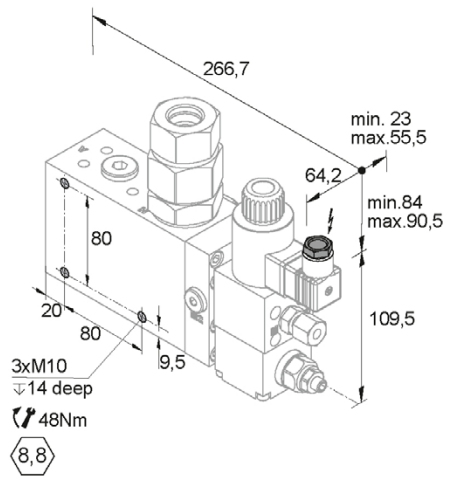

CAUTION!

Hydraulic hoses must not come into contact with the flow control valve as they will suffer thermal damage.

6.3.1 Tightening torque

	Thread A	Strength class	Thread depth B	Tightening torque Nm
Mounting bolts	M8	8.8	11	25
Mounting bolts	M10	8.8	13 (100ltr.) 14 (200ltr.)	48
SAE 3/4"	M10	8.8	18	50

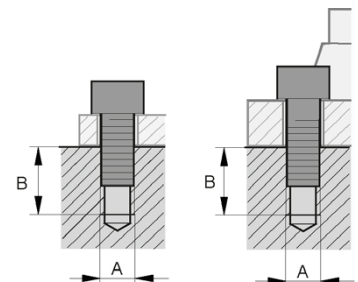

Montageschrauben
Mounting bolts

SAE Anschluß
SAE Connection



Attention:

Tightening torques must be observed. Torque wrench needed.

6.4 Setting the output flow rate

		Version 55 l/min	Version 100 l/min	Version 200 l/min
WARNING Maximum setting value (observe free thread length of the insert screw (2))				
ATTENTION During operation, the flow control valve can heat up to the oil temperature.				

NOTE: The counter-nut (3) is to be replaced after being used several times.

The flow rate for the attachment can be adjusted as follows:

- Ensure that the flow control valve is not under pressure
- Install the flow measurement device in the line (1) to the attachment
- Switch on the hydraulics
- Undo the counter-nut (3)
- Adjust the priority flow
 - Increase:** Turn the set-screw (2) to the left until the desired value is achieved
 - Decrease:** Turn the set-screw (2) to the right until the desired value is achieved
- Tighten the counter-nut (3)
- Switch off the hydraulics
- Depressurize the flow control valve
- Depressurize the attachment
- Remove the flow measurement device

6.5 Setting the pressure relief for the attachment



ATTENTION

During operation, the valve can heat up to the oil temperature.



CAUTION!

Do not unscrew the set-screws (1) more than 38 mm out of the housing. Do not loosen the screw-plug (3) while the flow control valve is under pressure.

NOTE

The counter-nut (2) is to be replaced after being used five times.

The maximum operating pressure of the attachment can be set between 100 – 320 bar.
The factory setting is 250 bar.

- Ensure that the flow control valve is not under pressure
- Remove the screw-plug (3)
- Connect the pressure gauge
- Switch on the hydraulics
- Undo the counter-nut (2)
- Adjust the maximum operating pressure of the attachment: **Increase:** Turn the set-screw (1) to the right. The maximum set-screw depth is restricted by the pin (4).
- Reduce:** Turn the set-screw (1) to the left.
- Tighten the counter-nut (2)
- Switch off the hydraulics
- Depressurize the flow control valve
- Remove the measurement device
- Screw the screw-plug (1) back in. Tightening torque 55 Nm
- Check tightness

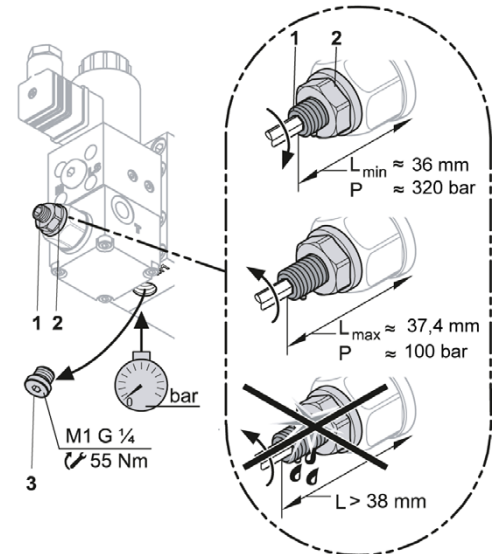

6.6 Dimensions

	Version 55 l/min	Version 100 l/min	Version 100 l/min (M27x2)	Version 200 l/min
A1	161,10	161,10	161,10	161,10
A2	33,50	33,50	33,50	33,50
A3	80,00	100,00	100,00	100,00
A4	57,50	62,00	72,3	83,50
B1	185,90	219,90	219,90	255,40
B2	135,50	169,50	169,50	205,00
B3	38,00	46,00	46,00	80,00
B4	16,00	20,00	20,00	11,00
B5	57,00	77,00	77,00	115,00
B6	19,00	24,00	24,00	47,00
C1	50,00	62,00	62,00	60,00
C2	25,00	31,00	31,00	30,00

7 Notes, Standards and Safety Requirements

7.1 General remarks

- The views in drawings are shown in accordance with the European normal projection variant

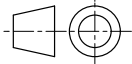

- A comma (,) is used as a decimal point in drawings
- All dimensions are given in mm

7.2 Standards

The following standards must be observed when installing and operating the valve:

- DIN EN ISO 13732-1:2008, Temperatures on accessible surfaces

8 Accessories

- Junior Timer plug part number 340.305.900.6
- Conversion set "hydraulically operated" 770.000.021.8
- Conversion set "permanently connected" 770.000.022.8

