



Table of Contents

1	Product Description	2
1.1	Function	2
1.2	Properties.....	2
2	Technical Data	3
3	Ordering Information	4
3.1	Type code	4
3.2	Versions currently available	4
4	Description of Characteristics in Accordance with Type Code	5
4.1	Characteristic 1: Design	5
4.2	Characteristic 2: Connections	5
4.3	Characteristic 3: Input flow rate	5
4.3.1	Pressure loss in relation to input flow rate	5
4.4	Characteristic 4: Maximum permissible pressure	5
4.5	Characteristic 5: Actuation	6
4.6	Characteristic 7: Preferred position.....	6
5	Installation	7
5.1	General remarks	7
5.2	Connection recommendations	7
5.3	Installation - space	7
5.4	Dimensions	8
6	Notes, Standards and Safety Requirements	9
6.1	General remarks	9
6.2	Standards.....	9
7	Accessories	9

1 Product Description

1.1 Function

In the unswitched state of the directional control valve, the main consumer (consumer 1) is activated. In the switched state, the new additional consumer (consumer 2) is operated. Switching is done hydraulically or electrically. In the electrical version the control pressure which is necessary for the switching is taken from one of the high-pressure inputs, so that no additional pilot pressure must be provided. If, due to the application, no pressure can be built up on both inputs, the valve in the electrical version can not switch.

In the unswitched position the input lines 1 and 2 are connected with outlet ports 3 and 4. In the switched position, the input lines 1 and 2 are connected to the outlet ports 5 and 6.

It should be noted that the respective non-connected outputs are blocked in the directional control valve 6/2 and thus there is no connection to any existing pressure relief valve in the input lines 1 and 2 respectively.

The 6/2 way valve is also available in an optional version with a transition position with negative overlap. During the switching operation, the terminals 1, 3, 5 or 2, 4, 6 are then briefly connected. Switching from a low pressure consumer to a consumer with a clamped pressure can result in a relaxation shock that can be reduced by the negative overlap.

The directional valves 6/2 are constructed as slide valves. They are not leak-free.

Connections:

- 1, 2 From the main control unit
- 5, 6 Consumer 1
- 3, 4 Consumer 2
- 7 Pump
- 8 Main Valve
- 9 Directional Control Valve
- 10 Consumer 1
- 11 Consumer 2
- VSTA, VSTB Hydraulic piloting ports
- L Leak oil (tank) closed. In the case of the electrically switched valves, the leak oil connection (L) only needs to be connected to leak oil if it cannot be ensured that an input connection (1 or 2) has a maximum pressure at the tank pressure level.

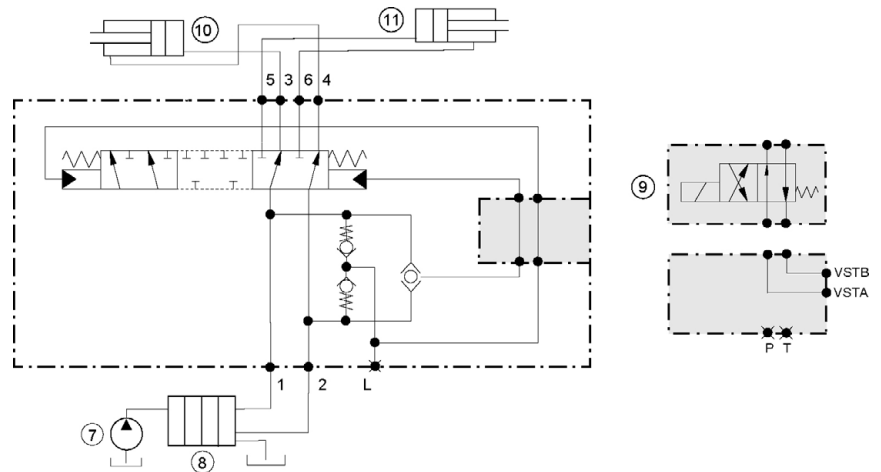

1.2 Properties

- Simple system extension with an additional function
- High switch reliability
- Simple installation between main control valve and two consumers
- Low pressure loss

2 Technical Data

critierion	units	value		
Installation position		any		
Weight	kg		elektric	hydraulic
		2S	6,3	5,5
		2M	8,9	8,1
		2L	14,2	13,4
Max. input pressure (P, A)	bar	350 optional 420		
Maximum recommended tank pressure (L)	bar	< 10 bar, recommended < 1bar		
Maximum input flow rate (P)	l/min	2S: 120, 2M : 250, 2L : 400		
Switching pressure (hydraulically operated version)	bar	minimum: 5; maximum 350		
Hydraulic fluid		mineral oil (HL, HLP) conforming with DIN 51524, other fluids upon request		
Leak oil rate	l/min	max. 0,2 (Leckage over control edge at 40°C und 200bar)		
Hydraulic fluid pressure range	°C	-20 to +80		
Ambient temperature	°C	< +50		
Viscosity range	mm ² /s	2.8 - 500		
Contamination grade		Filtering conforming with NAS 1638, class 9, with minimum retention rate $\beta_{10} \geq 75$		
Supply voltage	VDC	12 or 24		
Voltage tolerances	%	± 10		
Solenoid switch power consumption	W	33		
Solenoid switch flow rate consumption	A	2.9 at 12 VDC, 1.4 at 24 VDC		
Solenoid switch duty cycle	%	100		
Protection class according to DIN 40050		IP 65		
Current supply		ISO 4400 angle connector		

3 Ordering Information

3.1 Type code

D62							0	
00		01	02	03	04	05	06	07
00	product group	6/2					D62	
01	variant	standard Version, small size					2S	
		standard Version, medium size					2M	
		standard Version, maximum size					2L	
02	connections	version 2S	1,2,3,4,5,6 in G1/2" ISO 1179-1			03D		
		version 2M	1,2,3,4,5,6 in G3/4" ISO 1179-1			03E		
		version 2L	1,2,3,4,5,6 in G1" ISO 1179-1			03F		
03	input flow rate	version 2S	120 l/min			120		
		version 2M	250 l/min			250		
		version 2L	400 l/min			400		
04	max. permissible pressure	350 bar					350	
		420 bar					420	
05	actuation	electrical switching 12 VDC – connection via ISO 4400 angle plug connection					12S001	
		electrical switching 24 VDC – connection via ISO 4400 angle plug connection					24S001	
		hydraulic, connections G1/4 ISO1179-1.					HYS03B	
06	preferred position	6/2 directional valve, preferred position 1-3 or 2-4	version 2S, 2M, 2L			620		
		6/2 directional valve, preferred position, 1-3 or 2-4 negative coverage	Ausführung 2M, 2L			62N		
07	tank relief	without tank relief				version 2S, 2M, 2L	0	

XXX – Permanent preset characteristics XXX – Characteristics adjustable by customer
 available not available

3.2 Versions currently available

The versions listed below are available as standard. Further versions as part of the options given on the type code can be configured upon request. Therefore normally minimum order quantities are required.

Description	Type code	Part No.
D62-2L G1 400LPM 420BAR HYDR PRIO POS	D62- 2L- 03F- 400- 420 -HYS03B- 620- 0- 0	137.902.508.9
D62-2L G1 400LPM 420BAR 24VDC PRIO POS	D62- 2L- 03F- 400- 420 -24S001- 620- 0- 0	237.362.502.9
D62-2L G1 400LPM 350BAR 24VDC PRIO POS	D62- 2L- 03F- 400- 350 -24S001- 620- 0- 0	237.364.503.9
D62-2M G3/4 250LPM 420BAR HYDR PRIO POS	D62- 2M- 03E- 250- 420 -HYS03B- 620- 0- 0	135.902.503.9
D62-2M G3/4 250LPM 350BAR 24VDC PRIO POS	D62- 2M- 03E- 250- 350 -24S001- 620- 0- 0	235.362.552.9
D62-2M G3/4 250LPM 420BAR 24VDC PRIO POS	D62- 2M- 03E- 250- 420 -24S001- 620- 0- 0	235.362.553.9
D62-2S G1/2 150LPM 420BAR HYDR PRIO POS	D62- 2S- 03D- 150- 420 -HYS03B- 620- 0- 0	133.902.502.9
D62-2S G1/2 150LPM 350BAR 24VDC/ PRIO POS	D62- 2S- 03D- 150- 350 -24S001- 620- 0- 0	233.342.500.9
D62-2S G1/2 150LPM 420BAR 24VDC PRIO POS	D62- 2S- 03D- 150- 420 -24S001- 620- 0- 0	233.342.501.9

4 Description of Characteristics in Accordance with Type Code

4.1 Characteristic 1: Design

The valve is available in 3 versions:

- **2S** - small size (120 l/min)
- **2M** - medium size (250 l/min)
- **2L** - maximum size (400 l/min)

4.2 Characteristic 2: Connections

connection	2S	2M	2L
1,2,3,4,5,6	G ½ ISO 1179-1	G ¾ ISO 1179-1	G1 ISO 1179-1
L	M14 x 1,5 ISO 9974-1		
VSt A, VSt B	G ¼ (ISO 1179-1)		

4.3 Characteristic 3: Input flow rate

2S	120 l/min.
2M	250 l/min.
2L	400 l/min.

4.3.1 Pressure loss in relation to input flow rate

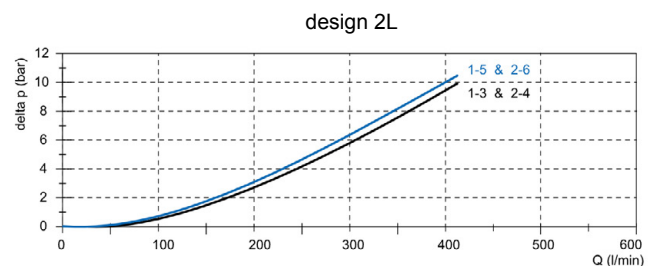
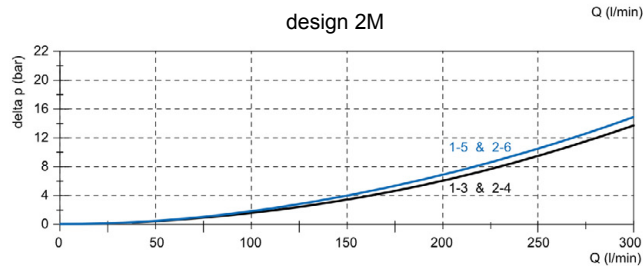
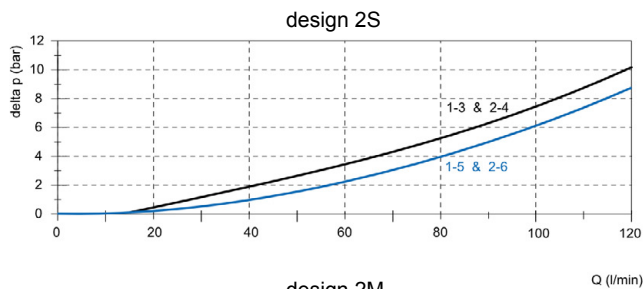

4.4 Characteristic 4: Maximum permissible pressure

Two versions of the valve are available: The standard variant with a maximum permissible pressure of 350 bar, the second with 420 bar.

4.5 Characteristic 5: Actuation

The valve can be actuated electrically or hydraulically



- The power supply (12 or 24 VDC) for the electrical variant is done via an angled plug connector ISO 4400
- In the hydraulically actuated version, the connection of the piloting signal is done via a G ¼ (ISO 1179-1) connection. The minimum switching pressure for the hydraulically operated valve is 5 bar. The maximum switching pressure must not exceed 350 bar.

4.6 Characteristic 7: Preferred position

The valve is available in two versions.

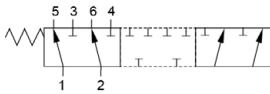

preferred position 1-3 & 2-4

Unswitched the valve is in a preferred position, the functionality corresponds with a 6/2 directional valve.



It should be noted that, in the case of loads acting on the non-switched consumer from the outside, pressure relief may not be effective.

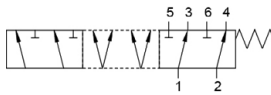

preferred position 1-3 & 2-4 with negative coverage.

5 Installation

5.1 General remarks

- All installation and safety information from the construction machine manufacturer are to be observed.
- Only technically permitted changes are to be made on the construction machine.
- The user must ensure that the device is suitable for the respective application.
- Application exclusively for the range of application specified by the manufacturer.
- Before installation or dismantling, the hydraulic system is to be depressurized.
- Settings are to be made by qualified personnel only.
- Opening is only to be performed with the approval of the manufacturer, otherwise the warranty is invalidated.
- No responsibility is taken for the correctness of these connection recommendations, the functionality and the technical details of the construction machine must be checked.
- In the case of the electrically switched valves, the leak oil connection (L) only needs to be connected to leak oil if it cannot be ensured that at least one of the input connections (1 or 2) has a pressure at the most on tank pressure level.



Safety note: In order to protect the internal pilot shuttle valve, the input pressures in connections 1 and 2 must not suddenly invers (e.g. by using a switched 4/2 or 4/3 directional valve in the input lines).

5.2 Connection recommendations

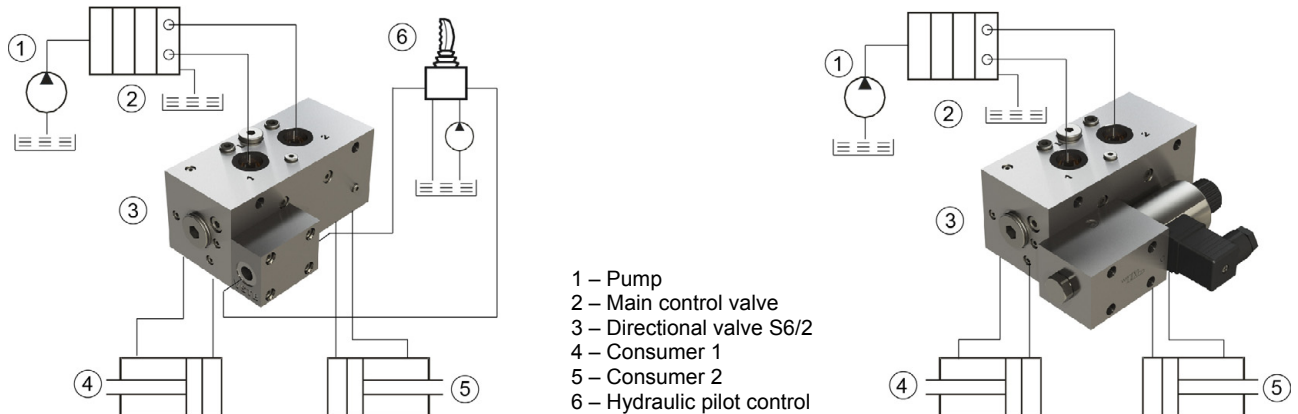

NOTE: The included connection recommendations are not guaranteed. The functionality and the technical specifications of the construction machine must be checked. It must be ensured that the construction machine is suitable in terms of technology and safety for the operation of the attachment.

5.3 Installation - space

- Ensure that the support element is level.
- Ensure that the valve is not bent during installation.
- Ensure that there is sufficient free space for setting and installation work.



CAUTION! Hydraulic hoses must not come into contact with the directional control valve as they will suffer thermal damage.

	Thread A	Strength class	Tightening torque installation Valve (Nm)	C (mm)
2S	M8	8,8	24,6	69,5
2M	M10	8,8	48	79,5
2L	M12	8,8	84	86,5

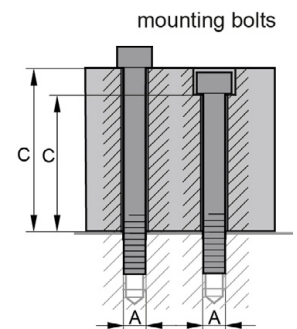

5.4 Dimensions

Version 2S - 120 l/min

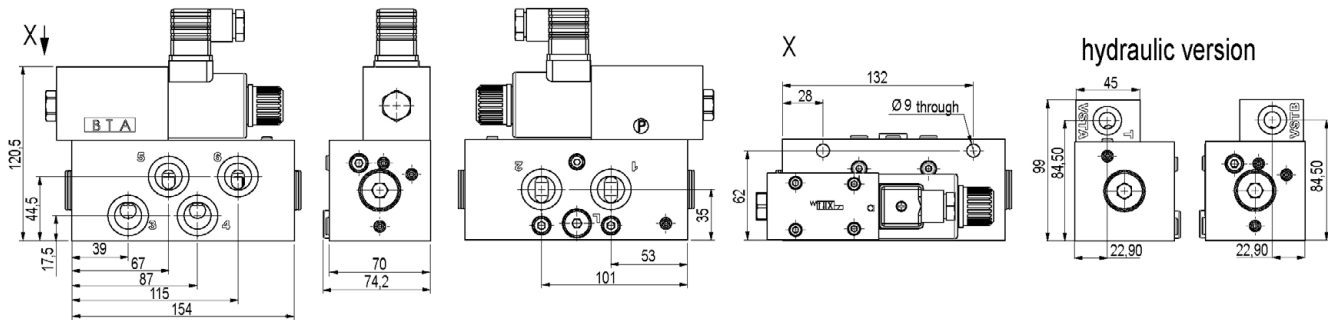

Version 2M - 250 l/min

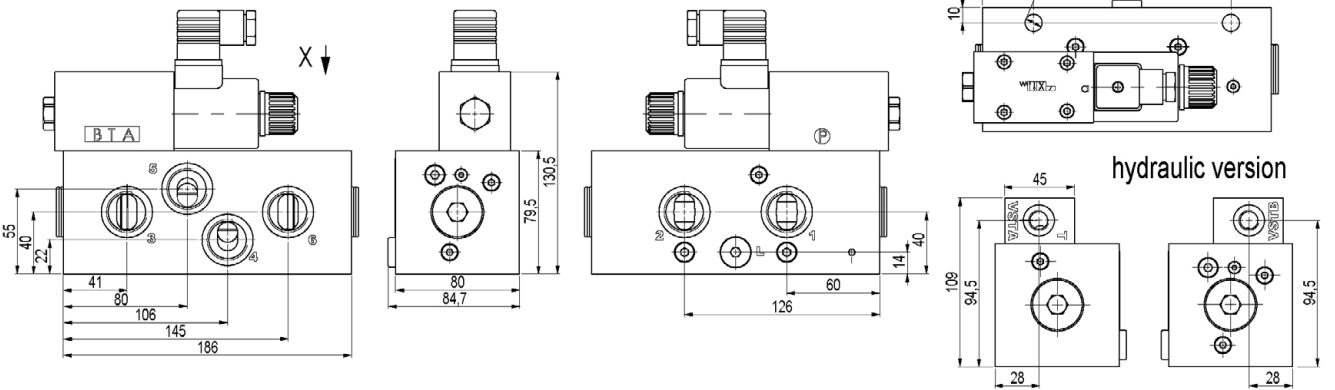

Version 2L - 400 l/min

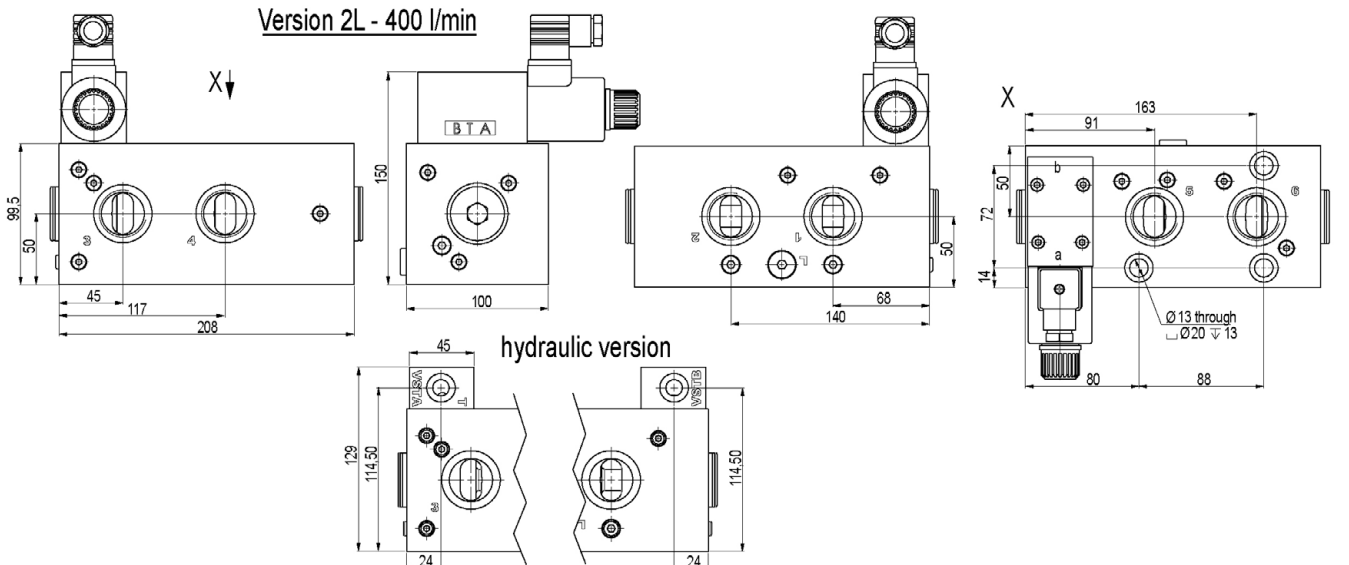

6 Notes, Standards and Safety Requirements

6.1 General remarks

- The views in drawings are shown in accordance with the European normal projection variant

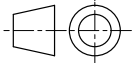

- A comma (,) is used as a decimal point in drawings
- All dimensions are given in mm

6.2 Standards

The following standards must be observed when installing and operating the valve:

- DIN EN ISO 13732-1:2008-12, Temperatures on accessible surfaces

7 Accessories