

DRAWING No. 016318			
ISSUE	CHANGE	DATE	CHK.
A		07.07	F.S
B		01.12	FS

DO NOT SCALE

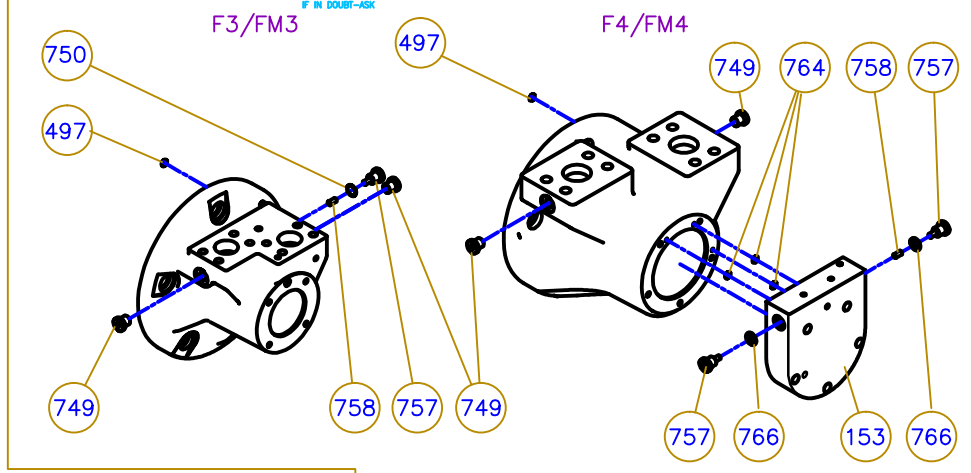
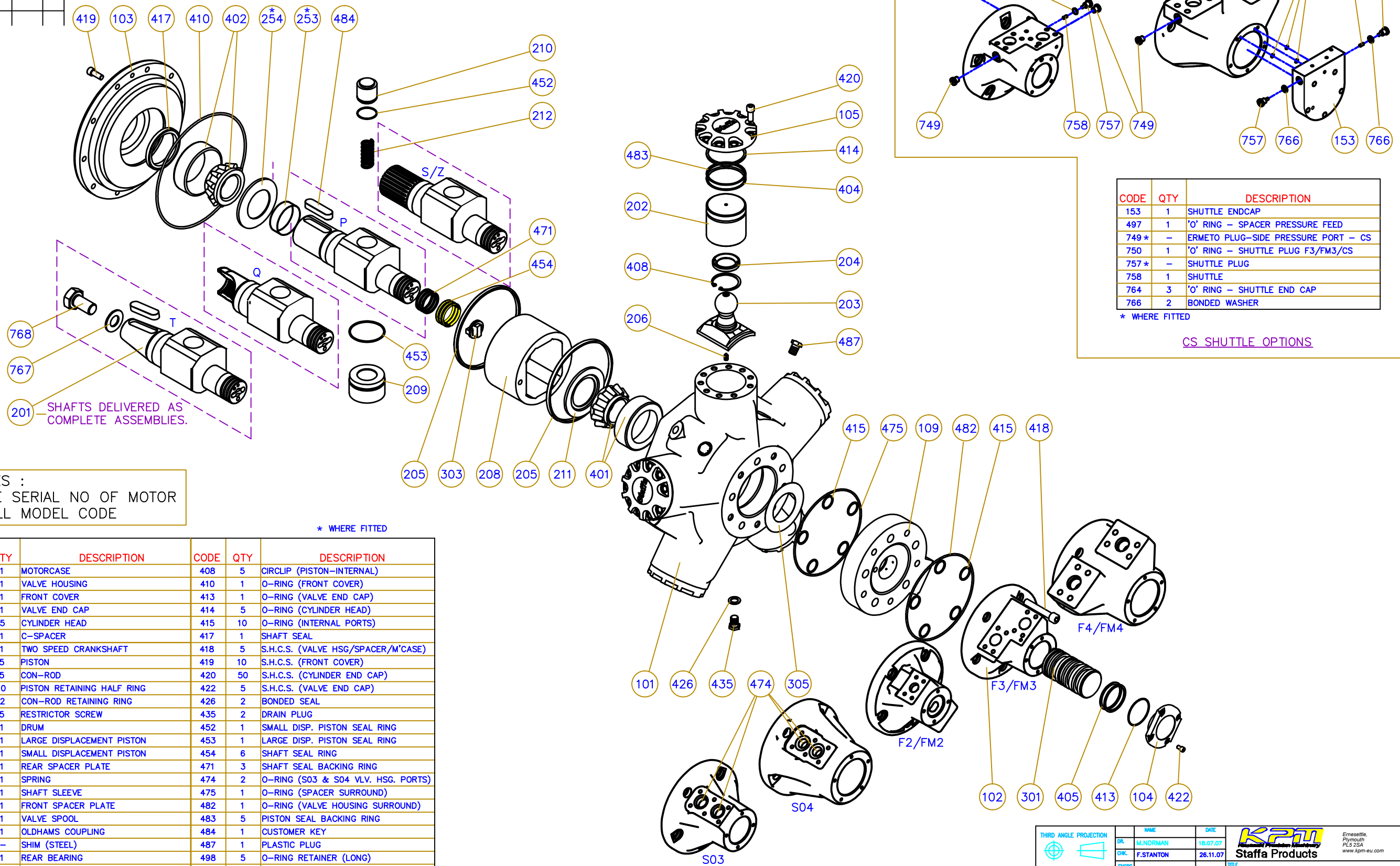

CODE	QTY	DESCRIPTION
153	1	SHUTTLE ENDCAP
497	1	'O' RING - SPACER PRESSURE FEED
749*	-	ERMETO PLUG-SIDE PRESSURE PORT - CS
750	1	'O' RING - SHUTTLE PLUG F3/FM3/CS
757*	-	SHUTTLE PLUG
758	1	SHUTTLE
764	3	'O' RING - SHUTTLE END CAP
766	2	BONDED WASHER

\* WHERE FITTED

CS SHUTTLE OPTIONS

SPARES :  
QUOTE SERIAL NO OF MOTOR  
+ FULL MODEL CODE

\* WHERE FITTED

CODE	QTY	DESCRIPTION	CODE	QTY	DESCRIPTION
101	1	MOTORCASE	408	5	CIRCLIP (PISTON-INTERNAL)
102	1	VALVE HOUSING	410	1	O-RING (FRONT COVER)
103	1	FRONT COVER	413	1	O-RING (VALVE END CAP)
104	1	VALVE END CAP	414	5	O-RING (CYLINDER HEAD)
105	5	CYLINDER HEAD	415	10	O-RING (INTERNAL PORTS)
109	1	C-SPACER	417	1	SHAFT SEAL
201	1	TWO SPEED CRANKSHAFT	418	5	S.H.C.S. (VALVE HSG/SPACER/M'CASE)
202	5	PISTON	419	10	S.H.C.S. (FRONT COVER)
203	5	CON-ROD	420	50	S.H.C.S. (CYLINDER END CAP)
204	10	PISTON RETAINING HALF RING	422	5	S.H.C.S. (VALVE END CAP)
205	2	CON-ROD RETAINING RING	426	2	BONDED SEAL
206	5	RESTRICTOR SCREW	435	2	DRAIN PLUG
208	1	DRUM	452	1	SMALL DISP. PISTON SEAL RING
209	1	LARGE DISPLACEMENT PISTON	453	1	LARGE DISP. PISTON SEAL RING
210	1	SMALL DISPLACEMENT PISTON	454	6	SHAFT SEAL RING
211	1	REAR SPACER PLATE	471	3	SHAFT SEAL BACKING RING
212	1	SPRING	474	2	O-RING (S03 & S04 VLV. HSG. PORTS)
253*	1	SHAFT SLEEVE	475	1	O-RING (SPACER SURROUND)
254*	1	FRONT SPACER PLATE	482	1	O-RING (VALVE HOUSING SURROUND)
301	1	VALVE SPOOL	483	5	PISTON SEAL BACKING RING
303	1	OLDHAMS COUPLING	484	1	CUSTOMER KEY
305	-	SHIM (STEEL)	487	1	PLASTIC PLUG
401	1	REAR BEARING	498	5	O-RING RETAINER (LONG)
402	1	FRONT BEARING	499	5	O-RING RETAINER (SHORT)
404	5	PISTON SEAL RING	767	1	KEEP PLATE
405	12	VALVE SEAL RING	768	1	HEX HEAD SCREW

THIRD ANGLE PROJECTION	NAME	DATE	
	DR. M.NORMAN	18.07.07	
	CHK. F.STANTON	26.11.07	<b>GENERAL ASSEMBLY (FOR SPARES)</b> <b>HMC/HPC MOTOR (030-200)</b>
	ENGR. APPL. WT.		
<small>ALL TECHNICAL DATA DISCLOSED HEREIN IS THE PROPERTY OF KPM/STAFFA AND SHALL NOT BE USED BY OTHERS FOR MANUFACTURE, PROCUREMENT OR DISCLOSURE WITHOUT THE WRITTEN PERMISSION OF THE OWNER.</small>			SIZE A1 SCALE NTS DRAWING No. 016318 SHEET 1 of 1