

4-Speed Radial Piston Staffa Motor HPC400

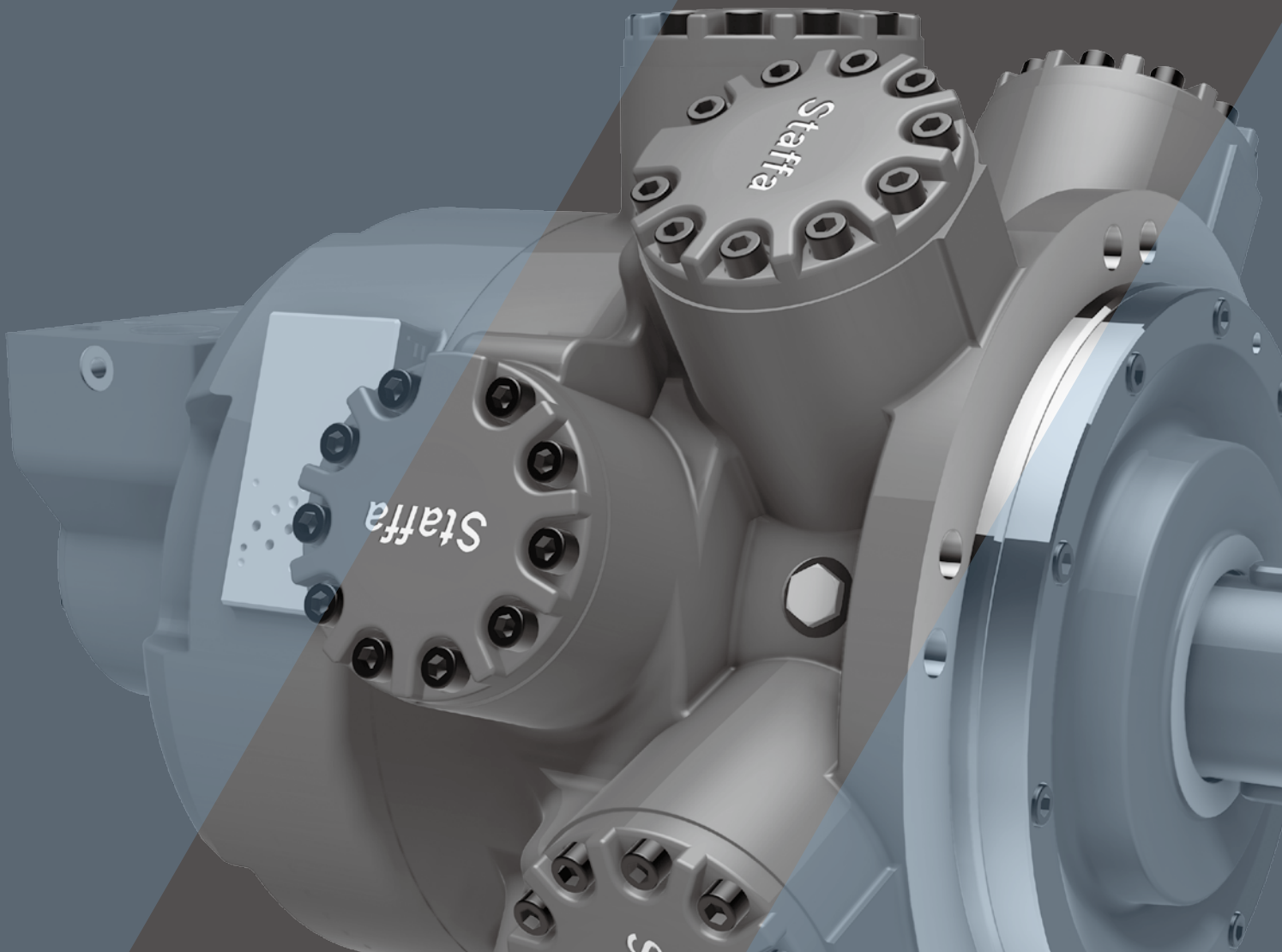

CONTENTS

Specifications and Features	2
1. Ordering Code	3
2. Technical Information	
2-1. Performance Data	4-5
2-2. Volumetric Efficiency Data	6
2-3. Crankcase Flushing Flow	7
2-4. Functional Symbols	8
2-5. Bearing Life Notes	8
2-6. Shaft Stress Limits	9
2-7. Circuit And Application Notes	10-12
2-8. Motor Operation At Low Temperature	13
2-9. Freewheeling Notes	14
2-10. Installation Data	15
2-11. Crankcase Drain Connections	16
2-12. Main Port Connections	17
3. Dimensions	
3-1. Installation	18
3-2. Shaft Options	19
3-3. Displacement Control Options	20

HPC Series

4-Speed Radial Piston Staffa Motors

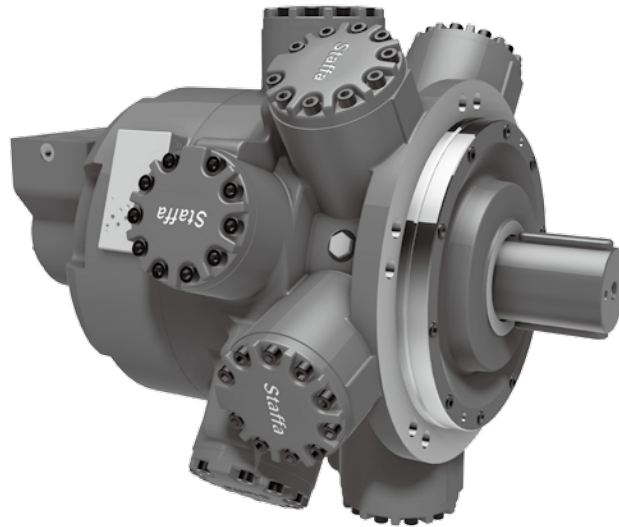

■ General Descriptions

Kawasaki "Staffa" high torque, low speed radial piston motors use hydrostatic balancing techniques to achieve high efficiency combined with good breakout torque and smooth running capability.

The HPC400 motor is designed to meet the needs of maritime equipment manufacturers in the 21st century.

The HPC400 motor has two eccentric drums which can be independently moved between high and low displacement positions via dual CETOP3 interfaces.

As part of the Staffa HPC range of motors, the HPC400 boasts a peak shaft power rating of 430 kW and a rated torque of 25,000 Nm. It also features the same high starting efficiencies, back pressure capabilities and dynamic displacement change of the HPC range.

■ Features

Max. Continuous Power of 430 kW

Smooth Operation at Low Speed

Dynamic Displacement Change

Rated Torque of 25,000 Nm

Freewheel Option available

Rugged Staffa Design

High Starting Torque

250 bar Continuous Rating

1

Ordering Code

HPC400/S5/200/05/200/05/SFM45/C/10/PL***

Shaft Type

S5	Spline 23T to S3550
Z5	Spline to DIN5480 W100 x 4 x 24 x 7h
P2	Parallel Key 100 mm Shaft dia

● See page 19

Front Displacement Code

High	Please specify* (200 max)
------	------------------------------

Front Displacement Code

Low	Please specify* (00 min)
-----	-----------------------------

Rear Displacement Code

High	Please specify* (200 max)
------	------------------------------

Rear Displacement Code

Low	Please specify* (00 min)
-----	-----------------------------

* With "00" Low Displacement setting the Maximum Available High Displacement setting is "195"

Special Features

For features not present in our standard catalog motor, e.g.

High Pressure Shaft Seal
Stainless Steel Shaft Sleeve

Consult with Sales for special requests

Design Series

Current design

This Number changes if there are design improvements which affect interchangeability of parts

C Spacer Type

Port face = Cetop 3, for mounting a Valve, to change displacement

● See page 20

Valve Housing Type

For Inlet/Outlet connections

● See page 17

2 Technical Information

2-1 Performance data

Performance data is valid for the HPC400 motors when fully run-in and operating with mineral oil.

The appropriate motor displacements can be selected using performance data shown on page 5.

If fluid to be used is not mineral oil, please contact KPM UK.

◆ Rating definitions

Continuous rating

The motor must be operated within each of the maximum values for speed, pressure and power.

Intermittent rating

Intermittent max pressure: 275 bar.

This pressure is allowable on the following basis:

- a) Up to 50 rpm 15% duty for periods up to 5 minutes maximum.
- b) Over 50 rpm 2% duty for periods up to 30 seconds maximum.

Static pressure to DNV rules 380 bar.

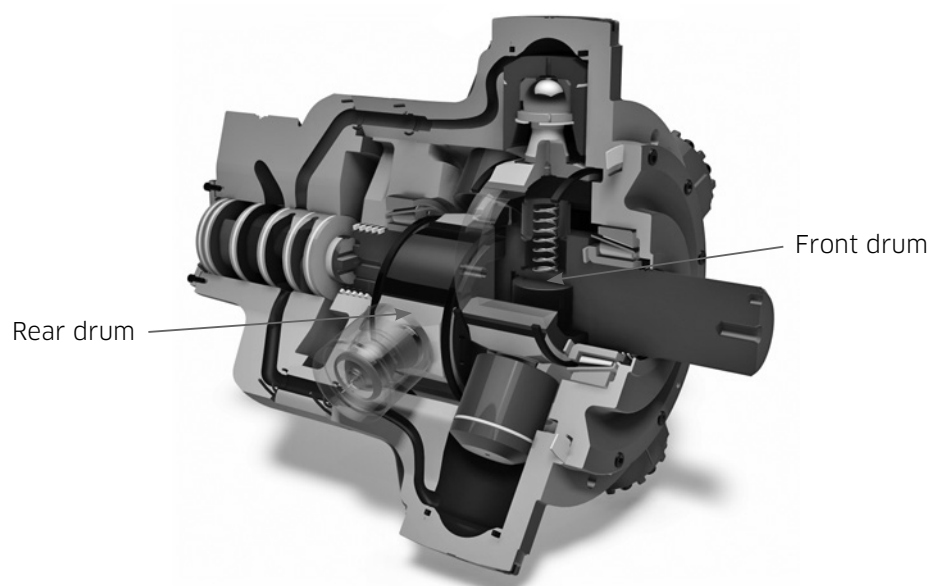

[Note]

The HPC400 motor has two banks of cylinder- two drums -referred to as 'front' and 'rear'.

The HPC400 motor may be specified with freewheel displacement on one or both of the front and rear drum positions. When the motor is in 'motoring' mode, one drum may be put into the freewheel displacement without restricting the motor's rated pressure.

2-1 Performance Data

Displacement Code		400	270	210	205	140	130	80	75	20	10
Displacement	cc/rev	6,555	4,425	3,441	3,59	2,294	2,130	1,311	1,229	328	164
Displacement (Front Bank)	cc/rev	3,277	3,277	3,277	3,277	1,147	1,147	1,147	1,147	164	82
Displacement (Rear Bank)	cc/rev	3,277	1,147	164	82	1,147	983	164	82	164	82
Average actual running torque	Nm/bar	100.0	66.1	51.3	50.1	34.1	31.4	19.6	18.1	3.6	0.0
Average actual mechanical efficiency	%	95.9	93.9	93.7	93.7	93.4	92.6	93.9	92.5	69.0	0.0
Average actual start torque	Nm/bar	91.6	60.0	44.0	42.7	26.9	23.5	11.4	10.2	/	/
Average actual start efficiency	%	87.8	85.2	80.3	79.9	73.7	69.3	54.6	52.1	/	/
Max continuous speed	rpm	220	220	220	220	460	460	460	460	630	1,500
Max continuous power	kW	430	315	265	260	245	230	105	95	20	10
Max continuous pressure	bar	250	250	250	250	250	250	250	250	250	20
Max intermittent pressure	bar	275	275	275	275	275	275	275	275	275	20

Displacement Code		390	195	00
Displacement	cc/rev	6,391	3,195	0
Displacement (front bank)	cc/rev	3,195	3,195	0
Displacement (rear bank)	cc/rev	3,195	0	0
Average actual running torque	Nm/bar	97.4	47.6	0
Average actual mechanical efficiency	%	95.8	93.6	0
Average actual start torque	Nm/bar	89.3	40.1	/
Average actual start efficiency	%	87.8	78.8	/
Max continuous speed	rpm	220	220	1,500
Max continuous power	kW	430	250	0
Max continuous pressure	bar	250	250	20
Max intermittent pressure	bar	275	275	20

Data shown is at 250 bar. Intermediate displacements can be made available to special order.

2-2 Volumetric Efficiency Data

Motor Type	Geometric Displacement	Zero Speed Constant	Speed Constant	Creep Speed Constant	Crankcase Leakage Constant	Fluid Viscosity	Viscosity Factor
HPC	l/rev	K_1	K_2	K_3	K_4	cSt	K_v
HPC400	6.555	9.7	30.0	1.1	10.1	20	1.58
						25	1.44
						30	1.30
						40	1.10
						50	1.00
						60	0.88

Q_t (total leakage)	=	$[K_1 + n/K_2] \times \Delta P \times K_v \times 0.005$	l/min
Creep speed	=	$K_3 \times \Delta P \times K_v \times 0.005$	rpm
Crankcase leakage	=	$K_4 \times \Delta P \times K_v \times 0.005$	l/min
ΔP	=	differential pressure	bar
n	=	speed	rpm

The motor volumetric efficiency can be calculated as follows:

$$\text{Volumetric efficiency (\%)} = \left[\frac{(\text{speed} \times \text{disp.})}{(\text{speed} \times \text{disp.}) + Q_t} \right] \times 100$$

Example:

HPC200 motor with displacement of 3.087 l/rev.

Speed	60 rpm
Differential pressure	200 bar
Fluid viscosity	50 cSt

$$\begin{aligned} \text{Total leakage} &= (K_1 + n/K_2) \times \Delta P \times K_v \times 0.005 \quad \text{l/min} \\ &= (6.1 + 60/38.5) \times 200 \times 1 \times 0.005 \\ &= 7.7 \quad \text{l/min} \end{aligned}$$

$$\begin{aligned} \text{Volumetric efficiency (\%)} &= \left[\frac{(60 \times 3.087)}{(60 \times 3.087) + 7.7} \right] \times 100 \\ &= \underline{\underline{96\%}} \end{aligned}$$

2-3 Crankcase Flushing Flow

In order to achieve the maximum shaft power, a crankcase flushing flow of 15 l/min should be directed through the motorcase. To improve the cooling effect of flushing flow, the distance between the inlet and outlet drain port connections should be maximised. If a flushing flow is not used, please consult KPM UK to verify performance parameters.

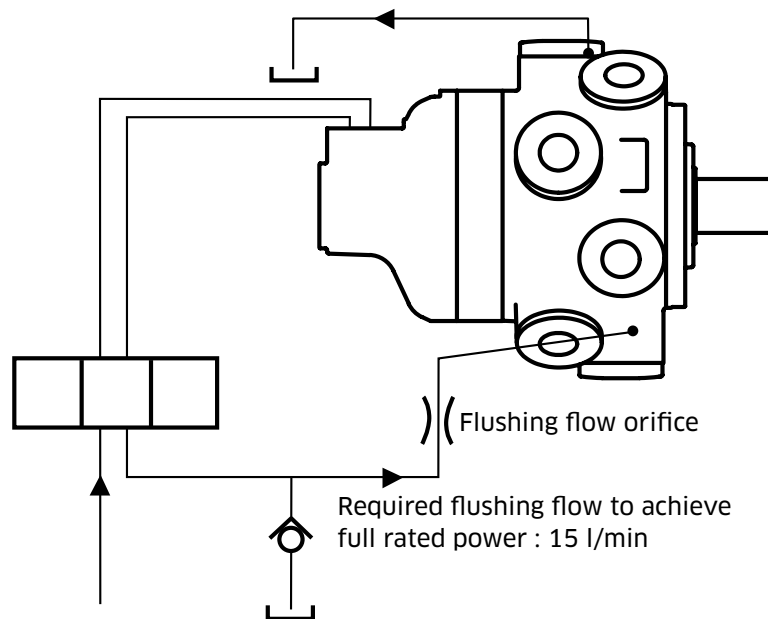

Check valve pressure (bar) *	Orifice diameter (mm)
3	4.4
4	4.1
5	3.9
6	3.7
7	3.6
8	3.5
9	3.4
10	3.3

* This assumes that the crankcase pressure is zero, if not then the check valve pressure will need to be increased to maintain the pressure drop across the orifice.

[Note]

If due to crankcase flushing flow, the crankcase pressure continuously exceeds 3.5 bar, then the motor build should include a high pressure shaft seal.

2-4 Functional Symbols

◆ Example model code:

HPC400 //**/**/**/**/PC/SFM45/C**

C - single external supply to PC port

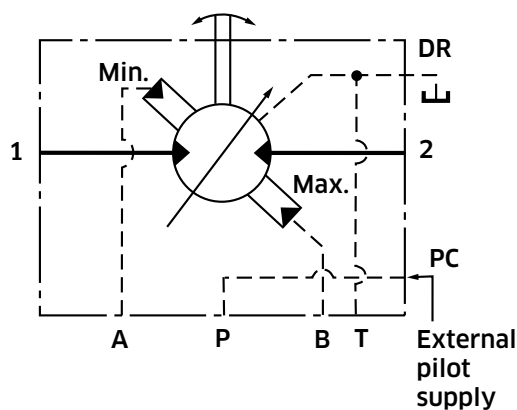

2-5 Bearing Life Notes

Consideration should be given to the required motor bearing life in terms of bearing service life. The factors that will determine bearing life include:

- 1) Duty cycle - time spent on and off load
- 2) Speed
- 3) Differential pressure
- 4) Fluid viscosity, type, cleanliness and temperature
- 5) External radial shaft load
- 6) External axial shaft load

If detailed bearing life calculations are required, please contact KPM UK, providing all of the above information.

2-6 Shaft Stress Limits

When applying large external radial loads, consideration should also be given to motor bearing lives, (see page 8).

Motor type	Maximum external radial bending moment (Nm)
HPC400	16,000

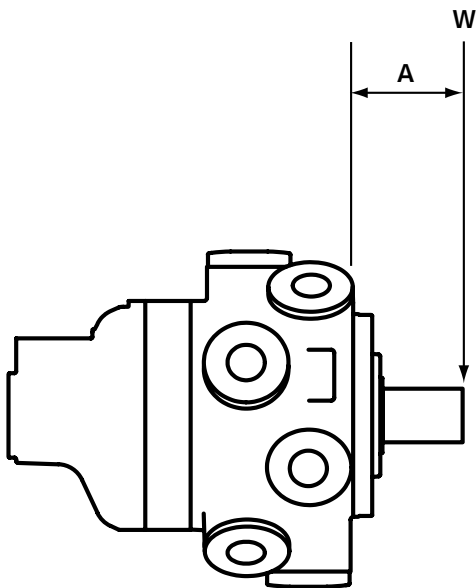

A = Distance from mounting face to load centre (m)

W = Side load (N)

Only example:

Determine the maximum radial shaft load of a HPC400 motor:

$$\begin{aligned}
 \text{Radial load offset, } A &= 0.1 \text{ m} \\
 \text{Maximum radial load, } W &= 16,000 \text{ (see table)}/0.1 \\
 &= \mathbf{160,000 \text{ N} = 160 \text{ kN}}
 \end{aligned}$$

2-7 Circuit and Application Notes

◆ Displacement selection

To select either displacement, a pressure at least equal to 67% of the motor inlet/outlet pressure (whichever is higher) is required. In most applications the motor inlet pressure will be used. If the inlet/outlet pressure is below 3.5 bar, a minimum control pressure of 3.5 bar is required. In the event of loss of control pressure the motor will shift to its highest displacement.

◆ Starting torque

Refer to performance data, (see page 5).

◆ Low speed operation

The minimum operating speed is determined by load inertia, drive elasticity, motor displacement and system internal leakage. If the application speed is below 3 rpm, then consult KPM UK. If possible, always start the motor in high displacement.

◆ Small displacements

The pressures given in the table on page 5 for displacement code "00" are based on 1,000 rpm output shaft speed. This pressure can be increased for shaft speeds less than 1,000 rpm; consult KPM UK

for details. Speeds greater than 1,000 rpm may be applied but only after the machine duty cycle has been considered in conjunction with KPM UK. A zero swept volume displacement (for freewheeling requirements) is available on request, consult KPM UK.

◆ High back pressure

When both inlet and outlet ports are pressurised continuously, the lower pressure port must not exceed 100 bar at any time. Note that high back pressure reduces the effective torque output of the motor.

◆ Boost pressure

When operating as a motor the outlet pressure should equal or exceed the crankcase pressure. If pumping occurs (i.e. overrunning loads) then a positive pressure, "P", is required at the motor ports. Calculate "P" (bar) from the boost formula:

$$P = 1 + \frac{N^2 \times V^2}{K} + C$$

Where P = boost pressure (bar), N = motor speed (rpm), V = motor displacement (cc/rev), C=Crankcase pressure (bar).

Motor	Porting	Constant (K)
HPC400	SFM45	101 x 10 ⁹

2-7 Circuit and Application Notes (cont)

◆ Motorcase pressure

The motorcase pressure should not continuously exceed 3.5 bar with a standard shaft seal fitted. On installations with long drain lines a relief valve is recommended to prevent over-pressurising the seal.

Notes

- 1) The motorcase pressure at all times must not exceed either the motor inlet or outlet pressure.
- 2) High pressure shaft seals are available to special order for casing pressures of: 10 bar continuous and 15 bar intermittent.
- 3) Check installation dimensions (page 18) for maximum crankcase drain fitting depth.

◆ Hydraulic fluids

Only mineral oil variant. For other fluids, please contact KPM UK.

2-7 Circuit and Application Notes (cont)

◆ Temperature limits

Ambient min. -30°C

Ambient max. +70°C

Max. operating temperature range.

Mineral oil

Min -20°C

Max. * +80°C

◆ Filtration

Full flow filtration (open circuit), or full boost flow filtration (close circuit) to ensure system cleanliness to ISO4406 code 18/14/- or cleaner.

◆ Noise levels

The airborne noise level is less than 67 dBA (DIN) through the “continuous” operating envelope. Where noise is a critical factor, installation resonances can be reduced by isolating the motor by elastomeric means from the structure and the return line installation. Potential return line resonance originating from liquid borne noise can be further attenuated by providing a return line back pressure of 2 to 5 bar.

◆ Polar moment of Inertia

Typical data:

Motor	Displacement code	Kgm ²
HPC400	200/200	0.390
	100/100	0.360
	200/05	0.360
	05/05	0.340

◆ Mass

HPC400 Approx. all models 594 kg.

2-8 Motor Operation at Low Temperature

When operating the motor at low temperature consideration should be given to the fluid viscosity. The maximum fluid viscosity before the shaft should be turned is 2,000 cSt. The maximum fluid viscosity before load is applied to the motor shaft is 150 cSt.

If low ambient temperature conditions exist, then a crankcase flushing flow of at least 5 l/min should be applied to the motor during periods when the motor is not in use.

The shaft seal temperature limits for both medium and high pressure applications are shown in the table below.

	Non-operating temperature limits	Minimum operating temperature
Standard pressure shaft seal	below minus 40°C and above 100°C	minus 30°C
High pressure shaft seal	below minus 30°C and above 120°C	minus 15°C

All seals are very brittle below minus 40°C and are likely to break very easily and due to their sluggish response may not provide a 100% leak free condition.

It should be noted that the maximum continuous operating temperature within the motor crankcase is plus 80°C.

2-9 Freewheeling Notes

All Staffa motors can be used in freewheeling applications. In all circumstances it is essential that the motor is unloaded (A and B ports connected together) and that the circuit is boosted.

The required boost pressure will be dependent on speed and displacement.

It should be noted that for motors in high displacement, large flows will re-circulate around the motor. This will require a large re-circulating valve and consideration of circuit cooling as the motor will generate a braking torque. It is for these reasons that 'C' series motors are the preferred option for freewheeling applications. It is normal to select displacement codes 10, 05 or 00.

Selecting the lowest available displacement of zero (00) will allow the motor shaft to be rotated at high speed without pumping fluid and with a minimum boost requirement. This will result in a minimum drive torque requirement for the freewheeling motor. Examples of the freewheeling feature on a winch are : dropping the load quickly in the case of an emergency and paying out cable. Consideration should be given when freewheeling such that the load does not drive the motor above its rated freewheeling speed.

The HPC400 motor may be specified with freewheel displacement on one or both of the front and rear drum positions. Choosing the freewheel option will limit maximum displacement to 390 cub.inches/rev. When the motor is in 'motoring' mode, one drum may be put into the freewheel displacement without restricting the motor's rated pressure.

◆ Displacement selection

If the motor inlet/outlet pressure is below 3.5 bar, then a minimum 3.5 bar control pressure is required in order to ensure that the motor remains in minimum displacement. It should be noted that in the event of loss of control pressure, the motor will shift to its highest displacement, which could result in damage to the motor. When freewheeling with displacement codes: 00, 05 or 10, it can be difficult to generate a 3.5 bar pressure. In these circumstances

it is necessary to feed the displacement change control circuit from a separate source thus ensuring a minimum control pressure of 3.5 bar. Under all operating conditions the control pressure port should be at least 2/3 of the motor inlet/outlet pressure ports.

◆ Boost requirement

The required boost pressure is detailed on page 10. The actual required level will be determined by the expected maximum speed in maximum displacement during the overrunning condition. A maximum motor and control pressure of 17 bar at 1,000 rpm is stated in the bulletins, although for purposes of freewheeling it is better to maintain a minimum boost level that satisfies all motor operating conditions. **The Staffa motor bulletin boost formulae does not apply to freewheeling displacements.** High boost levels will increase motor losses at the conrod slipper interface and valve assembly, which will increase the motor operating temperature.

The boost flow required should be sufficient to make-up circuit leakage loss and provide cooling for the pressure drop of recirculating flow.

◆ Crankcase cooling

The crankcase flushing flow of 15 l/min will control and reduce the temperature rise of the motor during the freewheeling operation. This should not be necessary for motor speeds upto 1,000 rpm. If operating at speeds above 1,000 rpm, then consult KPM UK.

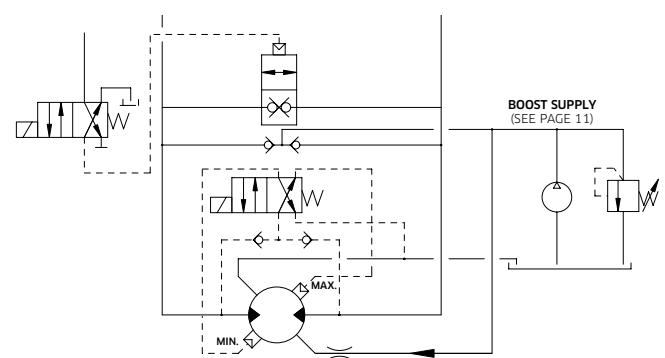

TYPICAL FREEWHEEL CIRCUIT
(EXAMPLE MODEL CODE - HPC400/S5/200/05/200/05/SFM45/C/10)

2-10 Installation Data

◆ General

Spigot

The motor should be located by the mounting spigot on a flat, robust surface using correctly sized bolts. The diametrical clearance between the motor spigot and the mounting must not exceed 0.15 mm. If the application incurs shock loading, frequent reversing or high speed running, then high tensile bolts should be used, including one fitted bolt.

HPC400 mounting flange incorporates 10 mounting holes as standard. If high tensile bolts are to be used, 5 bolts fitted at 72° intervals will be sufficient. If lower grade bolts are to be used it is recommended that 10 bolts are fitted.

Bolt torque

The recommended torque wrench setting for bolts is as follows:

M20	407 +/- 14 Nm	} Values for high tensile bolts.
¾" UNF	393 +/- 14 Nm	

Shaft coupling

Where the motor is solidly coupled to a shaft having independent bearings the shaft must be aligned to within 0.13 mm TIR.

Motor axis - horizontal

The crankcase drain must be taken from a position above the horizontal centre line of the motor, (see page 16).

Motor axis - vertical shaft down

Piping (from any drain port) must be taken above level of motorcase.

Bearing lubrication - piping

The installation arrangement must not allow syphoning from the motorcase. Where this arrangement is not practical, please consult KPM UK.

Any of the drain port positions can be used, but the drain line should be run above the level of the uppermost bearing and if there is risk of syphoning then a syphon breaker should be fitted.

◆ Start - up

Fill the crankcase with system fluid. Where practical, a short period (30 minutes) of "running in" should be carried out with the motor unloaded and set to its high displacement.

2-11 Crankcase Drain Connections

◆ Motor axis - horizontal

The recommended minimum pipe size for drain line lengths up to approx. 5m is 12.0 mm (½") bore. Longer drain lines should have their bore size increased to keep the crankcase pressure within limits.

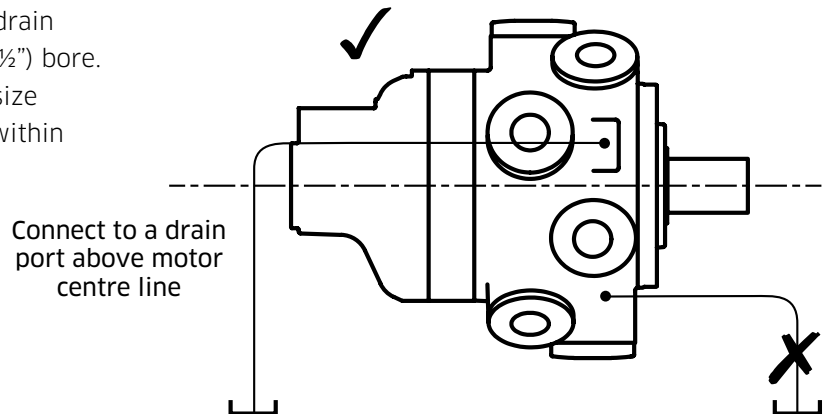

◆ Motor axis - vertical shaft down

The piping, from any drain port, must be taken above the level of the motorcase to ensure good bearing lubrication. The arrangement must not allow syphoning from the motorcase.

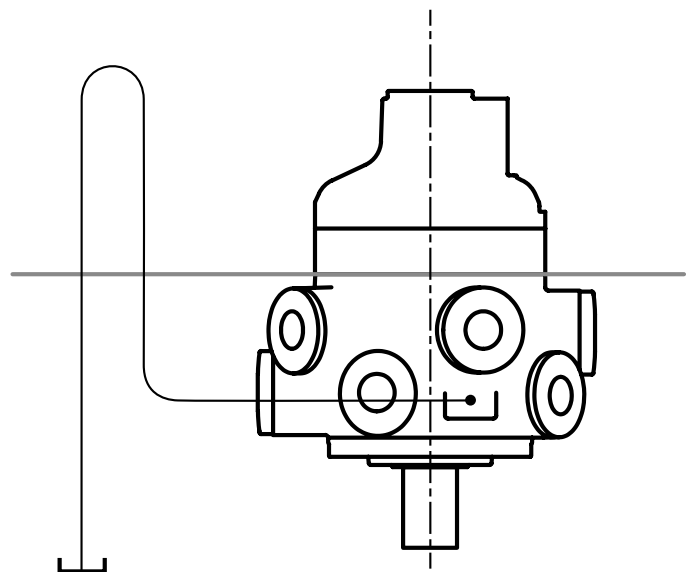

2-12 Main Port Connections

◆ Product type

HPC400

SFM45

=

2" SAE code 62 4-bolt flange

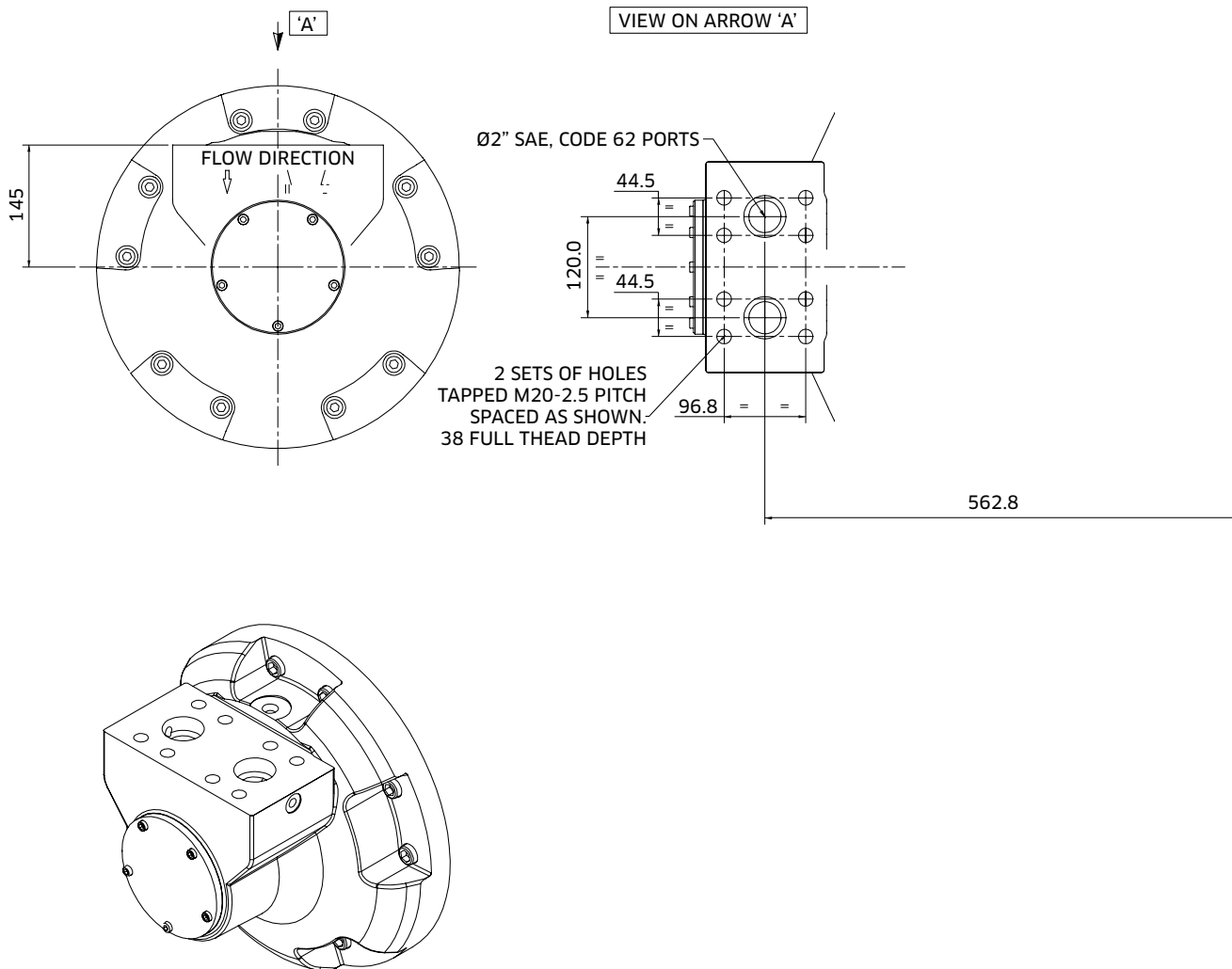

3 Dimensions

3-1 Installation

Example model code - HPC400/S5/200/05/200/05/SFM45/C/10

HPC400 mounting flange incorporates 10 mounting holes as standard. If high tensile bolts are to be used, 5 bolts fitted at 72° intervals will be sufficient. If lower grade bolts are to be used it is recommended that 10 bolts are fitted.

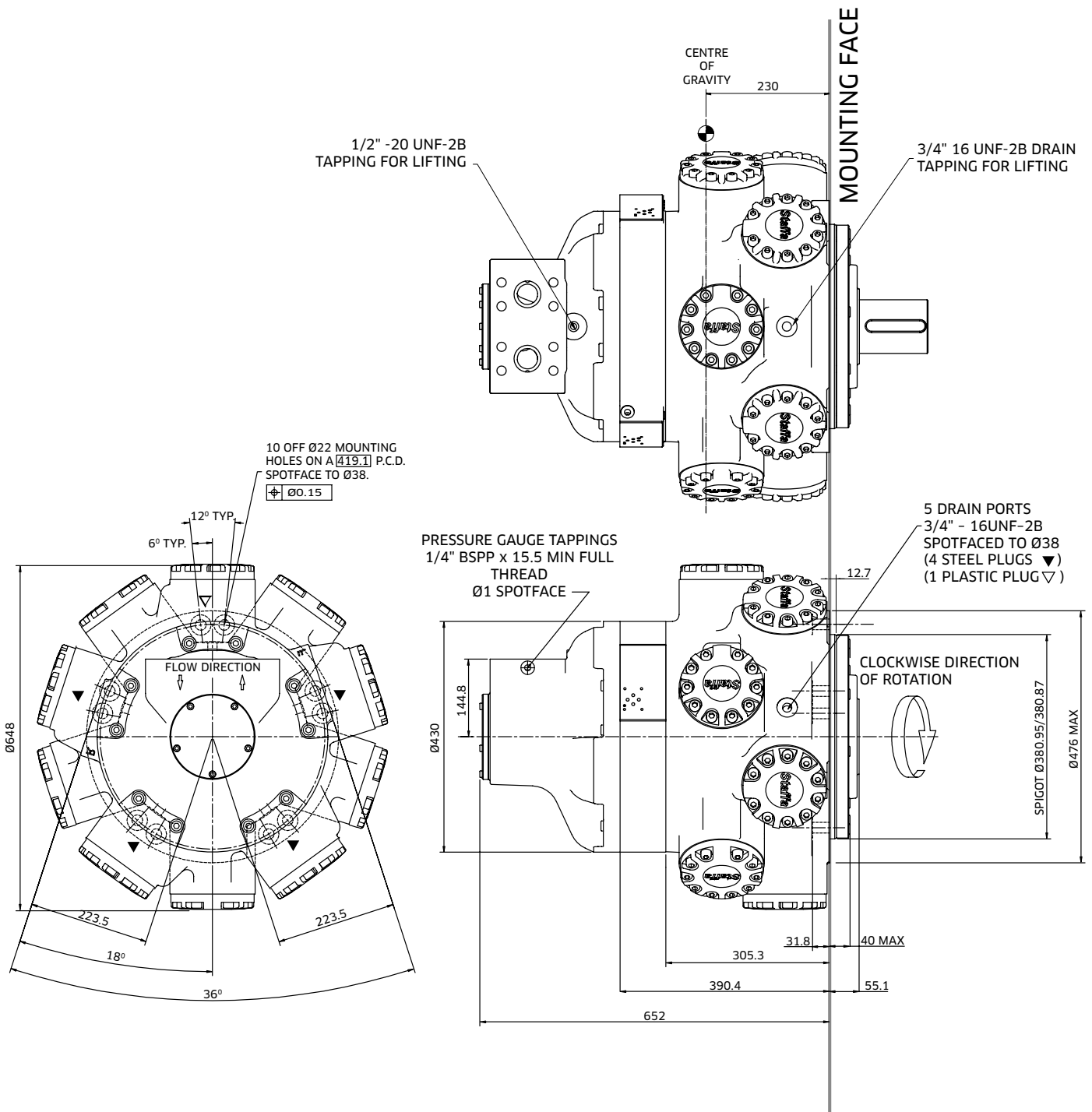

3-2 Shaft Options

Example model code - HPC400/S5/200/05/200/05/SFM45/C/10

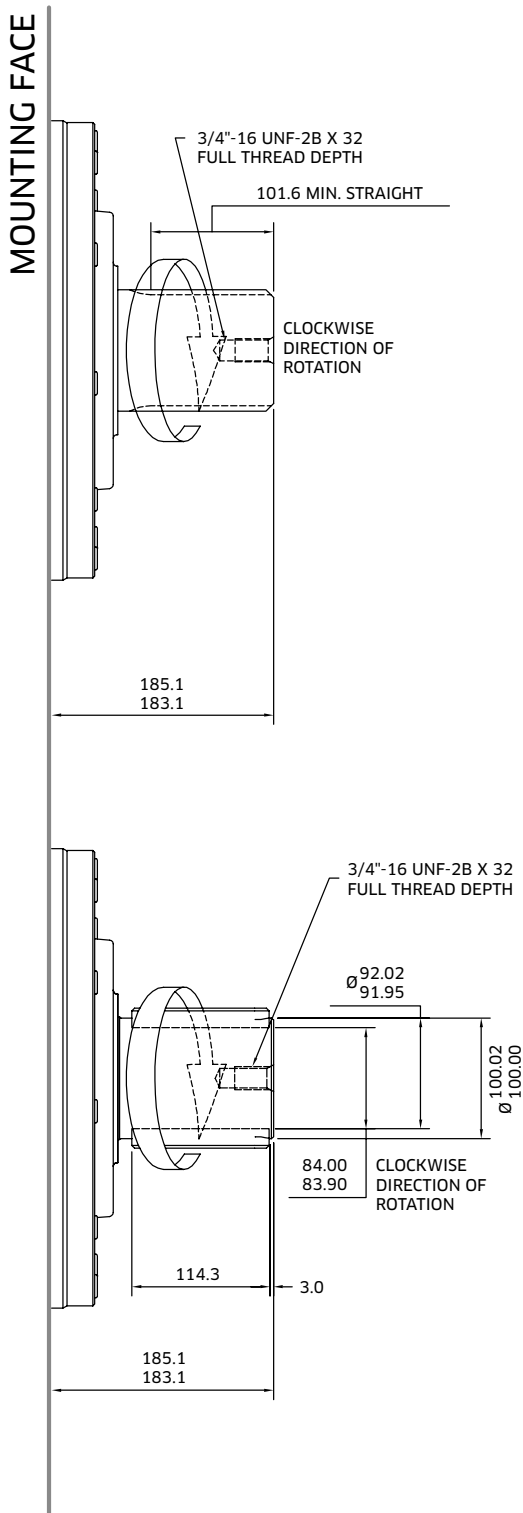

'S5'

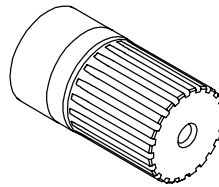

SPLINE DATA

EXTERNAL INVOLUTE SPLINE TO BS3550-1963 FLAT ROOT, SIDE FIT, CLASS 1	
NUMBER OF SPLINES	23
PRESSURE ANGLE	30°
PITCH	6/12
FORM DIAMETER	3.6590mm
BASE DIAMETER	3.3198mm
MAJOR DIAMETER	3.9627/3.9577mm
MINOR DIAMETER	3.6293/3.6073mm
MEASURING PIN DIAMETER	0.3200mm
DIAMETER ACROSS PINS	4.3140/0.2569mm
CIR. TOOTH WIDTH	0.2583/0.2569mm
MAX ALIGNMENT ERROR	+0.0005-0.0007mm
FILLET RAD	0.026mm

'P2'

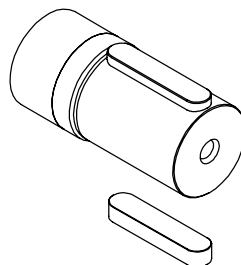

2 KEYS SUPPLIED -
24.066/24.000 WIDE
16.05/16.00 THICK

3-3 Displacement Control Options

Example model code - HPC400/S5/200/05/200/05/SFM45/C/10

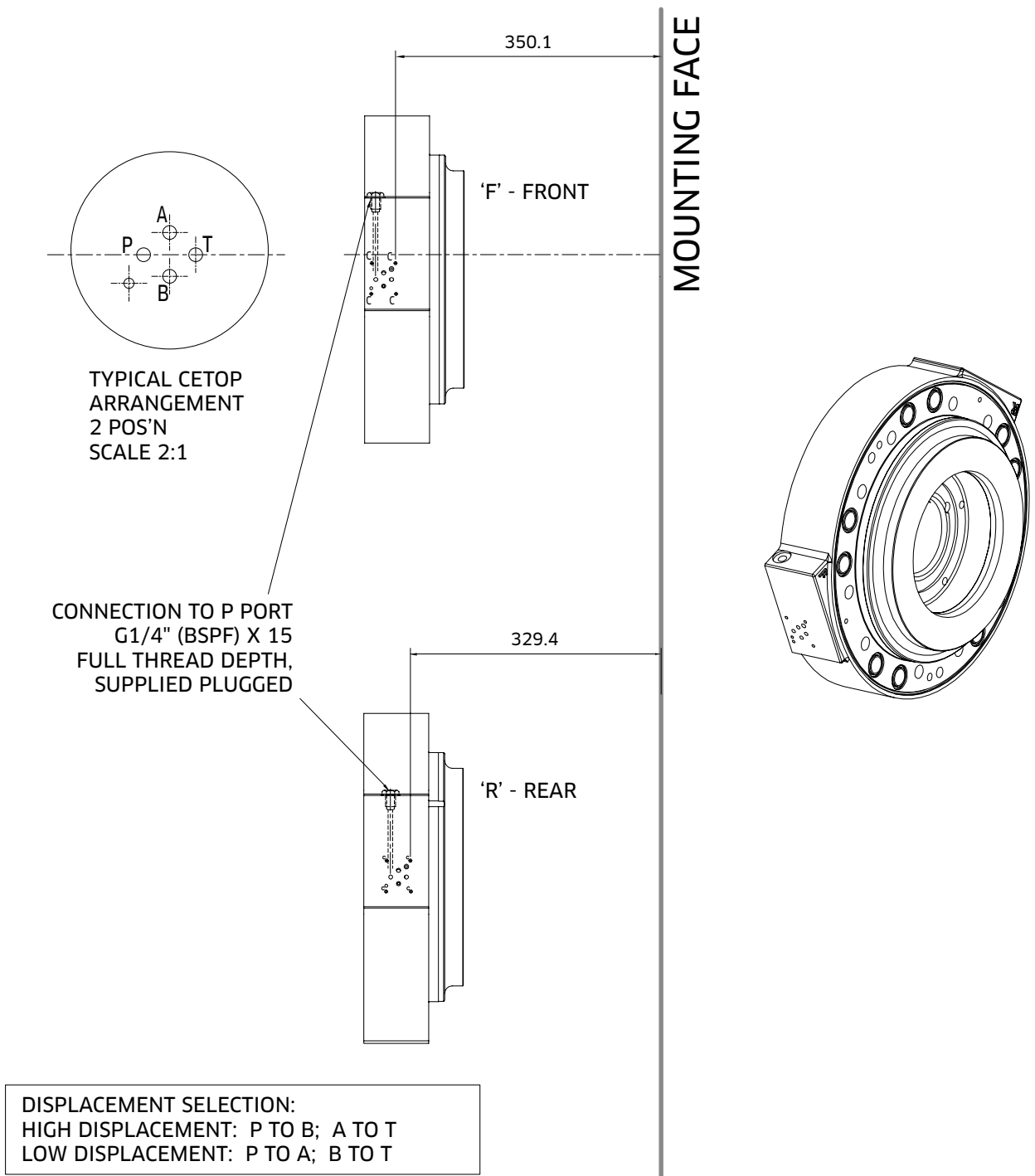

NOTES

NOTES

**KAWASAKI PRECISION
MACHINERY (UK) LTD**

Ernesettle, Plymouth
Devon, PL5 2SA, England

Tel: +44 1752 364394

Fax: +44 1752 364816

Mail: info@kpm-uk.co.uk

Website: www.kpm-eu.com

OTHER GLOBAL SALES OFFICES

JAPAN

Kawasaki Heavy Industry Ltd, Precision Machinery Ltd.
Tokyo Office World Trade Center Bidg.

4-1 Hamamatsu-cho

2-chome, Minato-ku

Tokyo 105-6116

Japan

Tel: +81-3-3435-6862

Website: www.khi.co.jp/kpm

U.S.A

Kawasaki Precision Machinery (U.S.A.), Inc.

3838 Broadmoor Avenue S.E.

Grand Rapids

Michigan 49512

U.S.A.

Tel: +1-616-975-3101

Website: www.kpm-usa.com

CHINA

Kawasaki Precision Machinery Trading (Shanghai) Co., Ltd.

17th Floor (Room 1701), The Headquarters Building

No168 XiZang Road (M)

Huangpu District

Shanghai 200001

China

Tel: +86-021-3366-3800

KOREA

Flutek, Ltd.

192-11, Shinchon-dong

Changwon

Kyungnam 641-370

Korea

Tel: +82-55-286-5551

Website: www.flutek.co.kr

**The specified data is for product description purposes only
and may not be deemed to be guaranteed unless expressly
confirmed in the contract.**